

4

3

2

1

D

D

C

C

B

B

A

A

REVISIONS				
ZONE	REV	DESCRIPTION	DATE	APPROVED

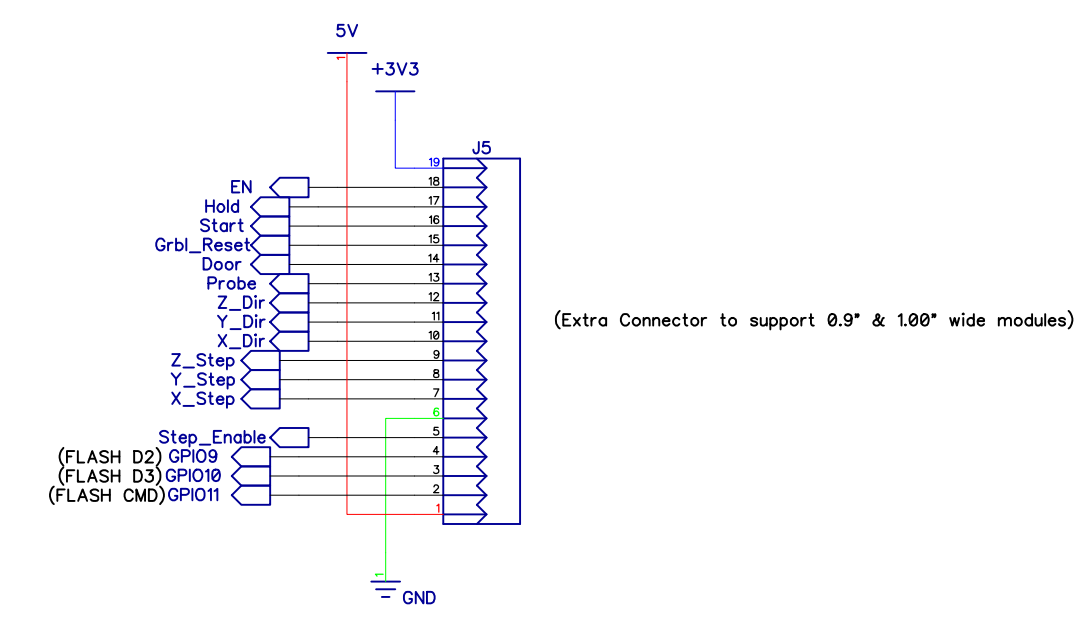
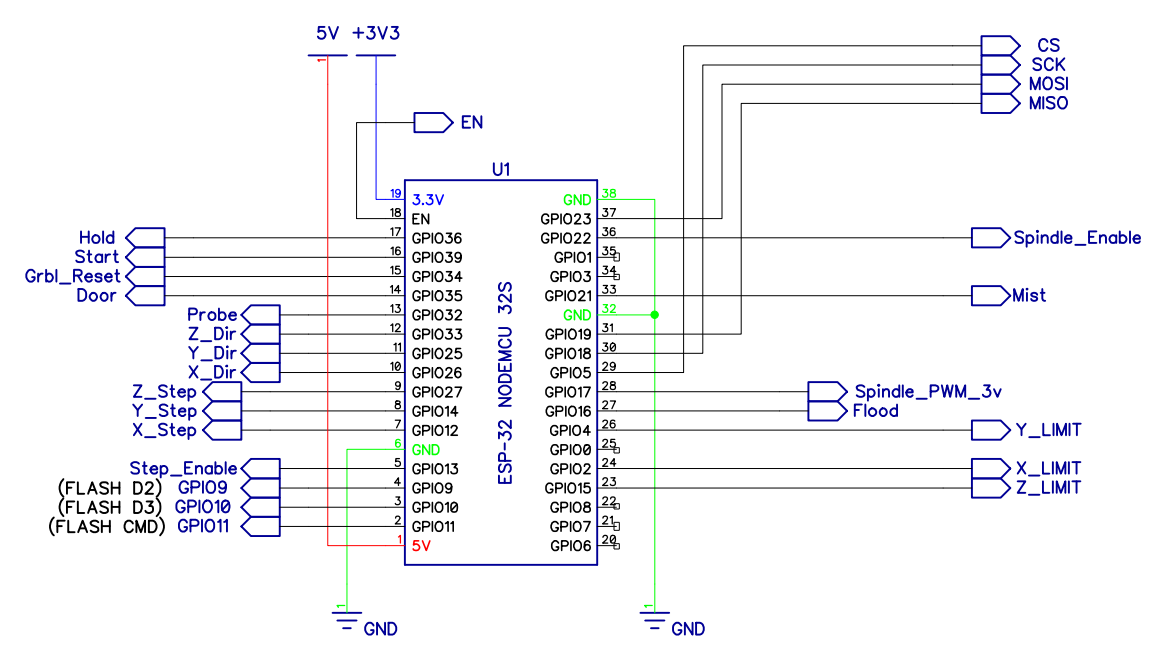

ESP32 Module

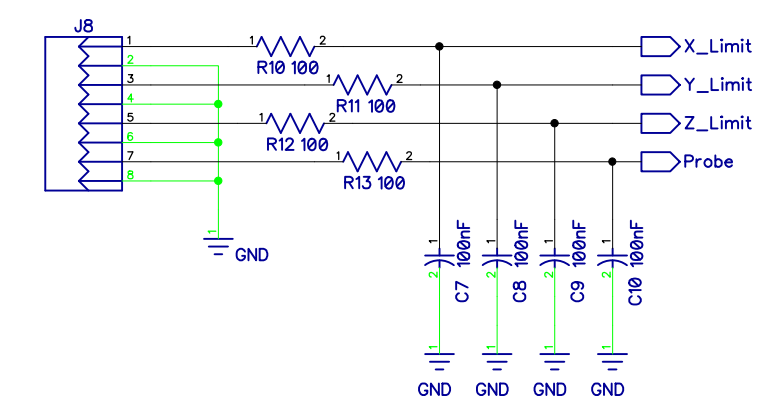
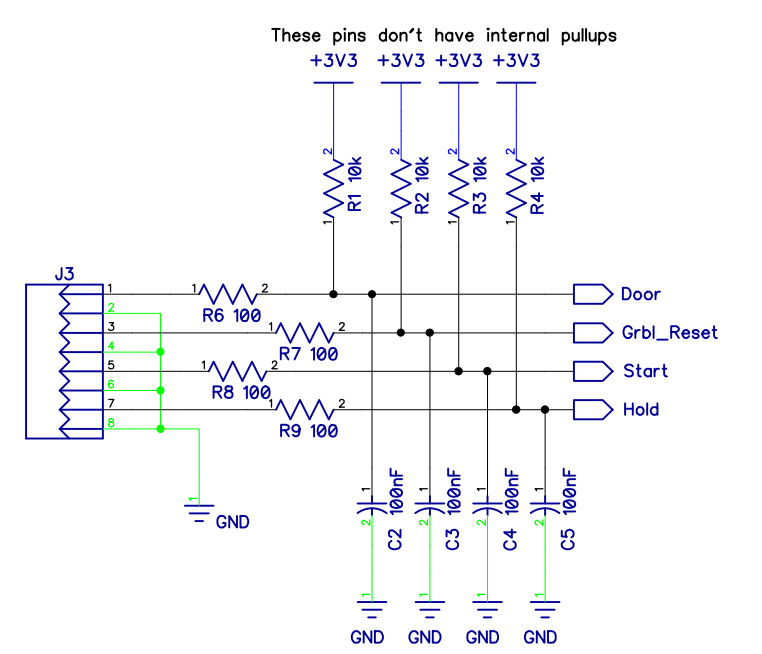

Inputs

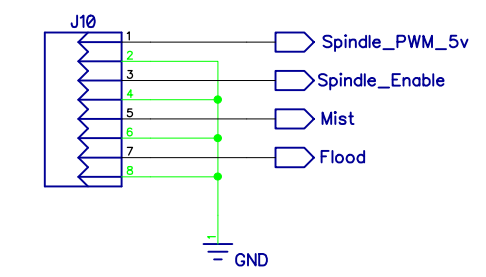

Outputs

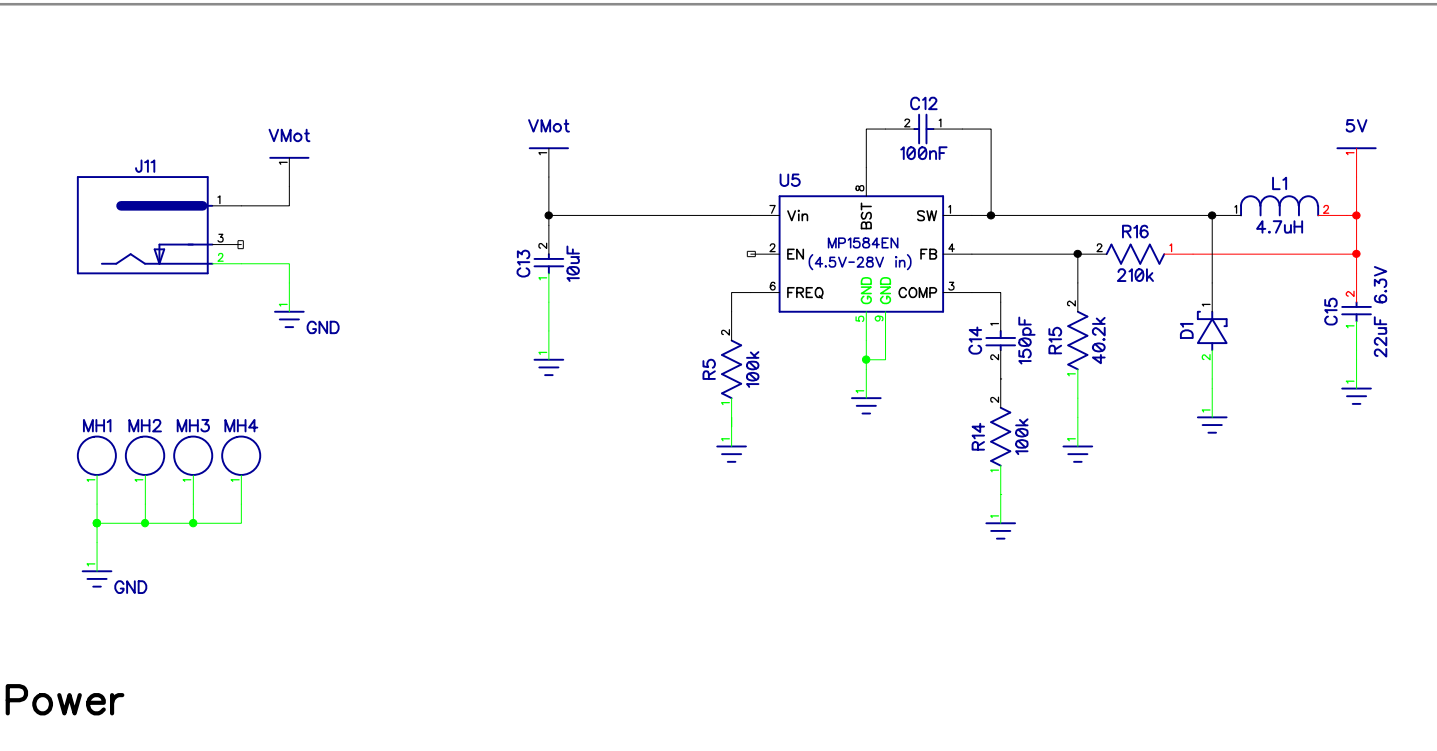

Power

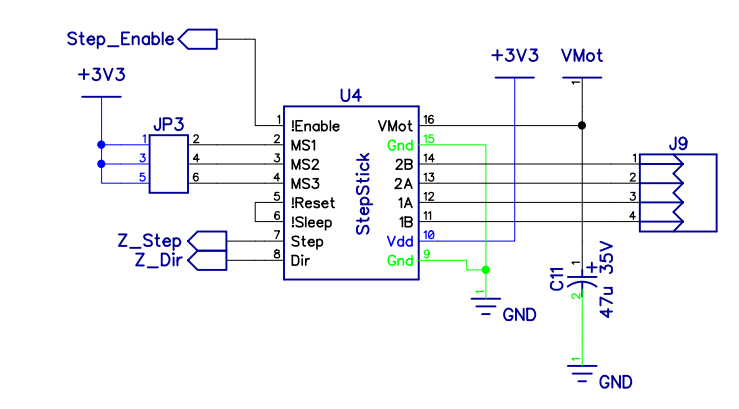
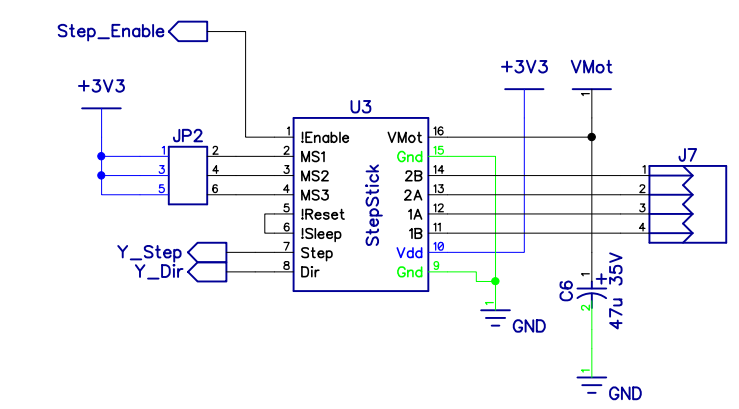
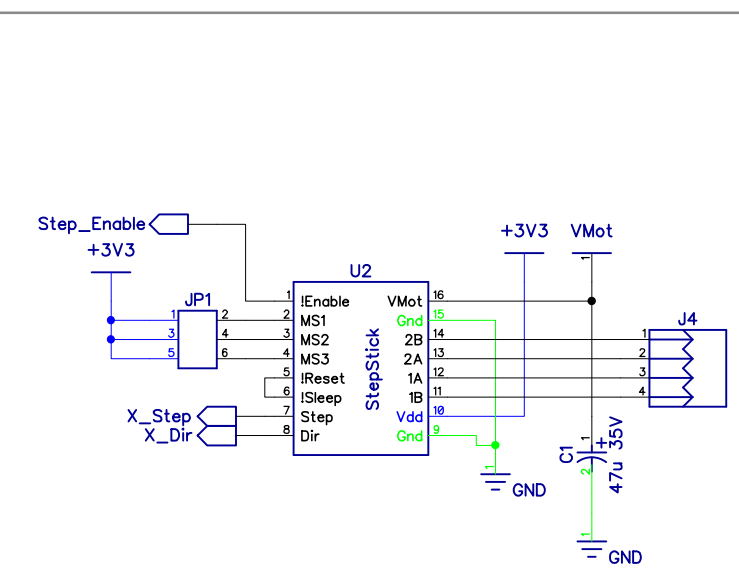
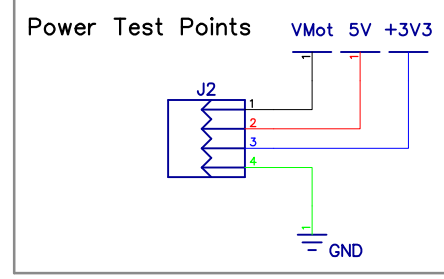
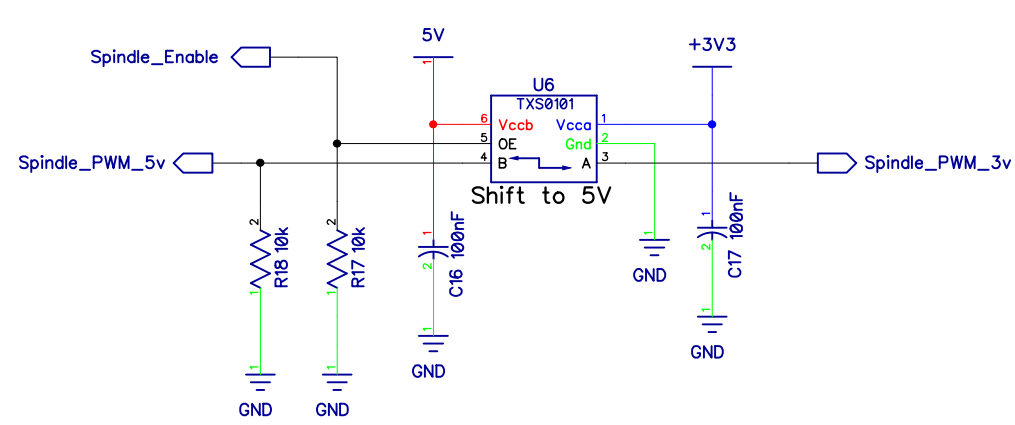

Stepper motor Drivers

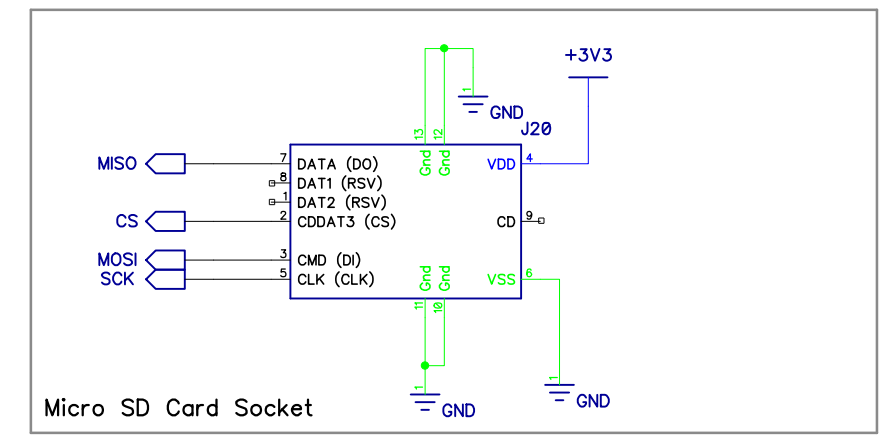

Micro SD Card Socket

ESP32 CNC Test PCB V3.5				
A Test PCB for Grbl-ESP32				
Buildlog.net	SIZE	FSCM NO.	DWG NO.	REV 3.1
	SCALE		Sheet 1	