

REVISIONS				APPROVALS		
SYM	DESCRIPTION	BY	DATE	ENGRG	PROD	Q.A.
1	ORIGINAL	BJD	3/2/10			
2	Changed X axis clamp	BJD	5/2/10			

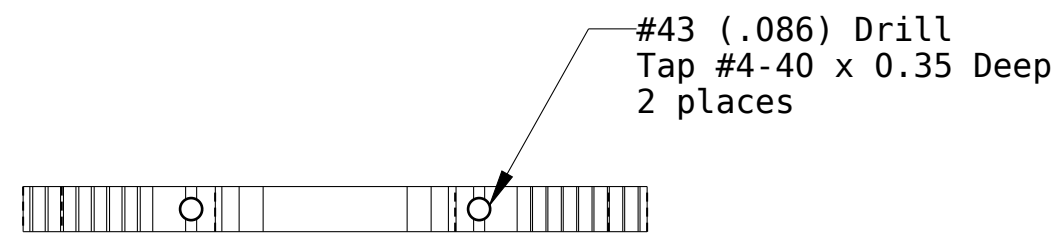

X AXIS BELT CLAMP

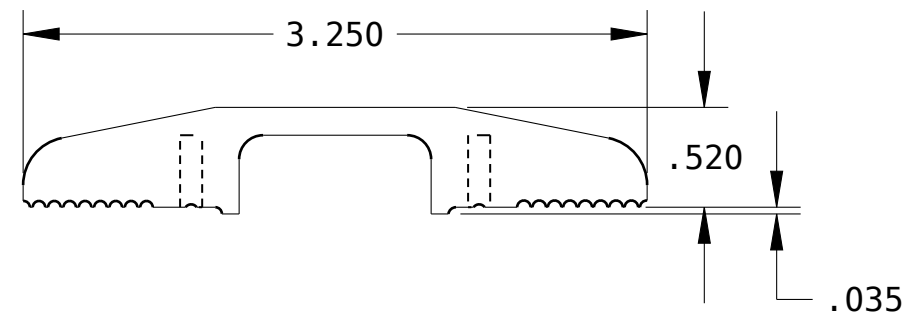
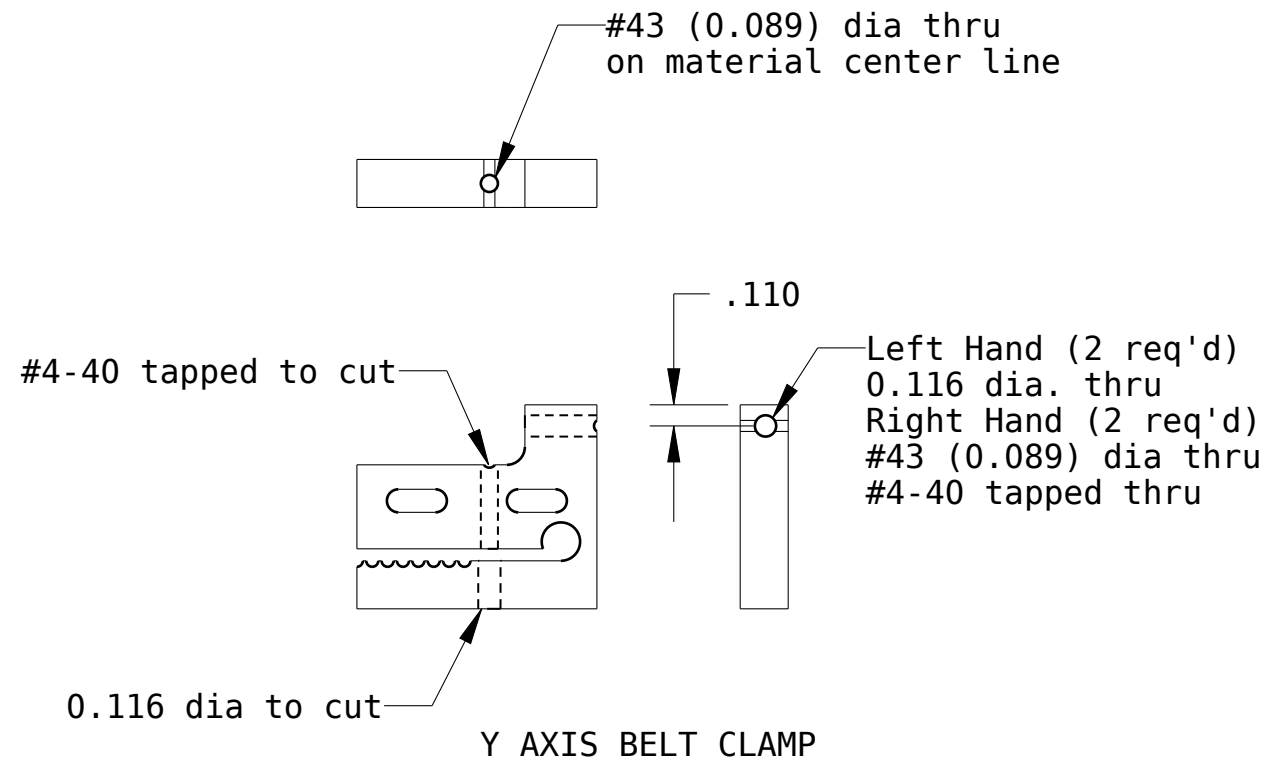

CAUTION: Material can easily crack. Peck drill and remove material often to prevent heat build-up and binding. Back out tap every few turns and clear material to prevent binding.

This work is licensed under a Creative Commons Attribution-Noncommercial-Share Alike 3.0 License

UNLESS OTHERWISE SPECIFIED:	
FRACTIONAL ± 1/32	DO NOT SCALE
DECIMAL .XXX ± .010	
ANGULAR .XX ± .020 ± 1/2°	
MATERIAL: 6mm Acrylic	
SPEC:	
FINISH:	
SPEC:	

DRAWN	BJD	3/2/10
CHECKER		
MECH. ENGR.		
ELEC. ENGR.		
PROJ. ENGR.		
CHIEF ENGR.		

BELT CLAMPS

SCALE

www.buildlog.net

BELT_CLAMPS

SHEET 1 OF 1