

REVISIONS			
SYM	DESCRIPTION	BY	DATE
1	ORIGINAL		
2	UPDATED	BJD	9/6/09
3	REVISED	BJD	2/19/10
4	Added note 2, remove end tapping in gantry	BJD	2/25/10
5	Added cover and table extrusions change center base extrusions to 2040	BJD	4/25/10
6	Fixed quantity's for z table extrusions	BJD	6/3/10

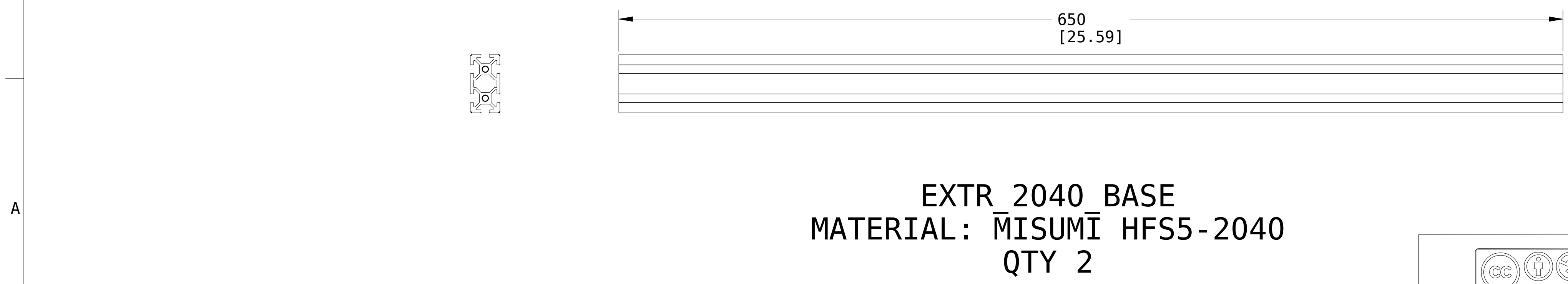
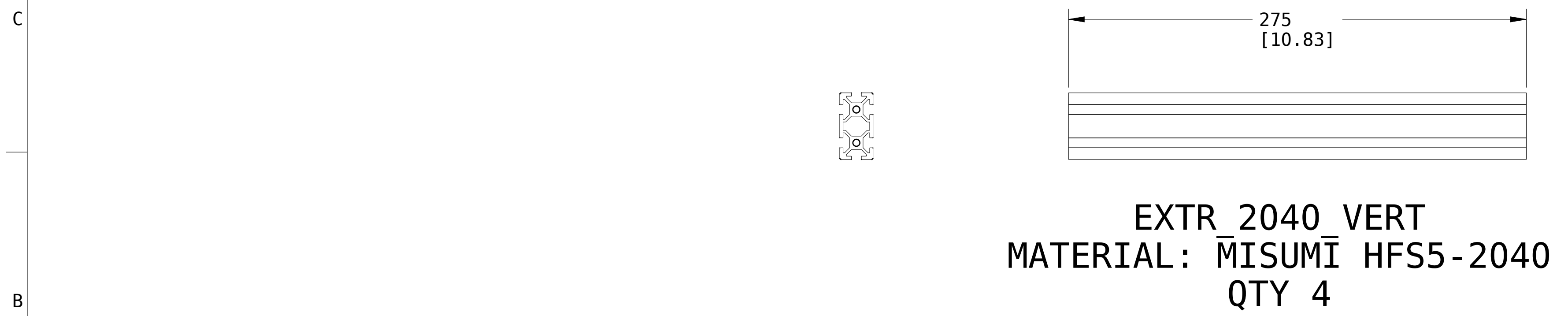
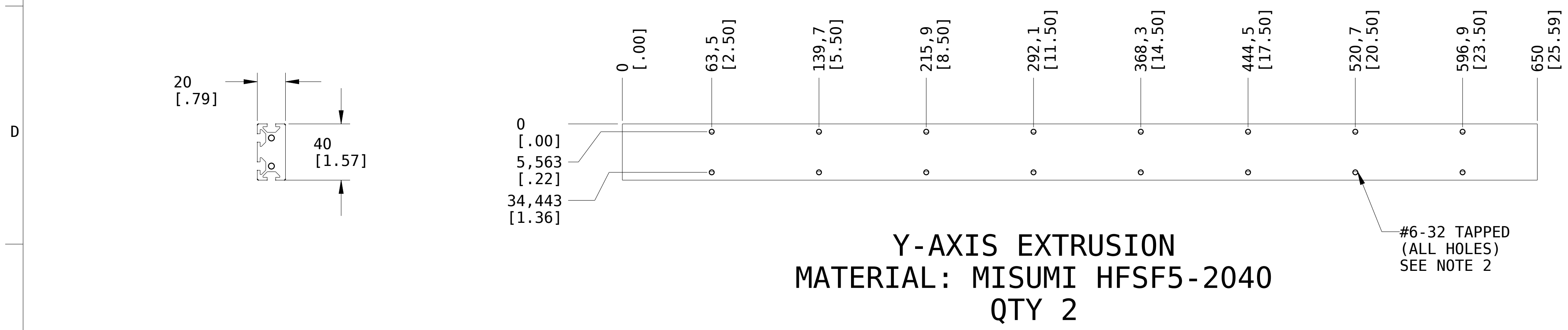
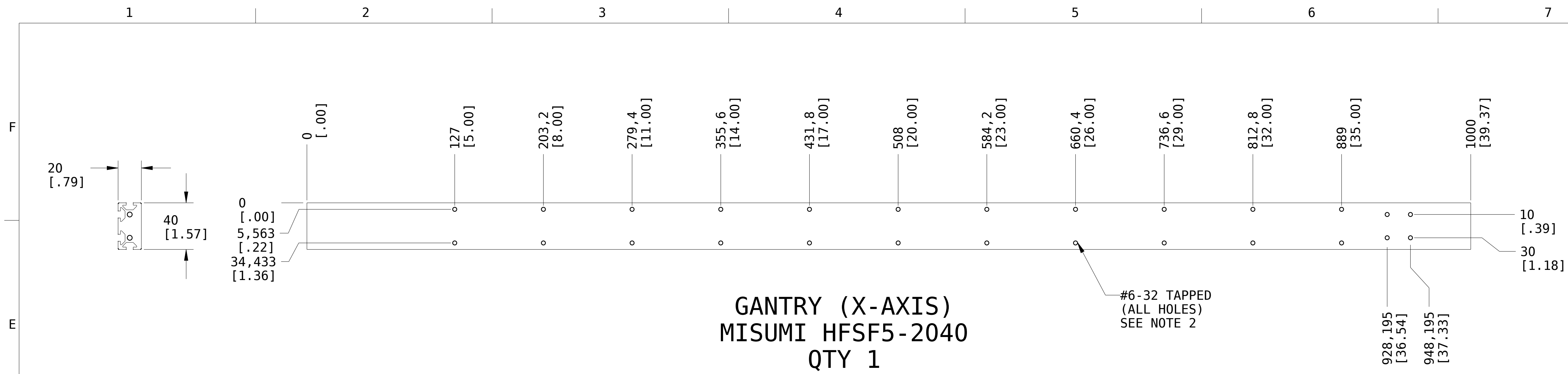

**Notes:**

1. All dimensions are actual per the design. Misumi will cut for free to the nearest mm. That should be fine for this machine.
2. Consider fabrication the V-Rails first. They can be used as a template for drilling the extrusions. This will insure that they match.

<p>This work is licensed under a Creative Commons Attribution-NonCommercial-Share Alike 3.0 License</p>	UNLESS OTHERWISE SPECIFIED:	DRAWN	BJD	8/15/09	<p><b>FRAME EXTRUSIONS</b></p> <p>www.buildlog.net</p> <p><b>EXTRUSIONS</b></p>
	FRACTIONAL ± 1/32	DO NOT SCALE	CHECKER		
	DECIMAL .XXX ± .010		MECH. ENGR.		
	ANGULAR .XX ± .020 ± 1/2°		ELEC. ENGR.		
MATERIAL SPEC:		PROJ. ENGR.			
FINISH SPEC:		CHIEF ENGR.			

REVISION	
SYM	DESCRIPTION
6	SEE SHEET 1

F

EXTR\_2020\_1  
 MAT'L: MIŠUMI HFS5-2020  
 QTY 2

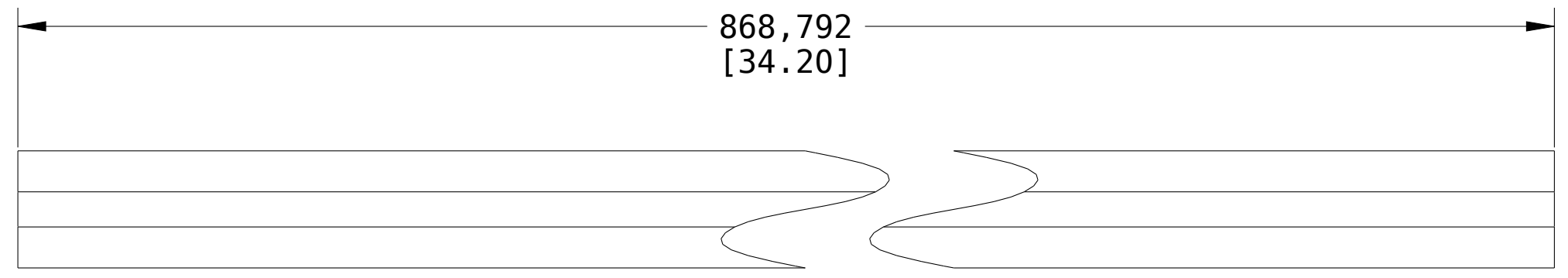
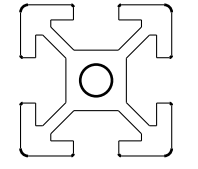

E

EXTR\_2020\_2  
 MAT'L: MIŠUMI HFS5-2020  
 QTY 4

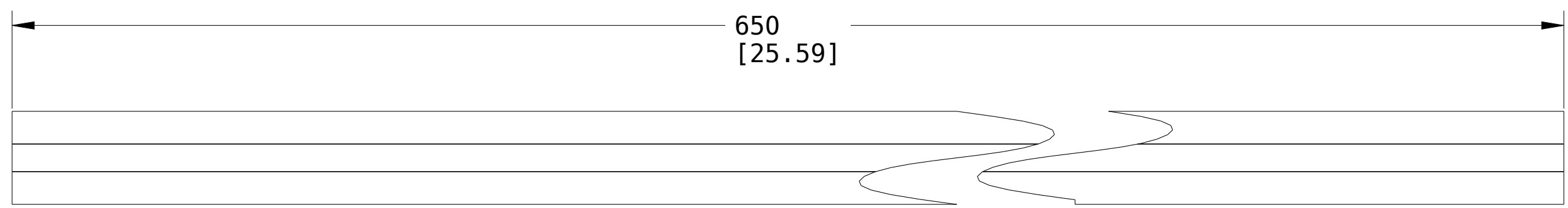
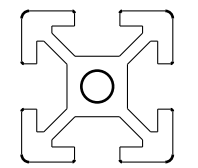

D

EXTR\_2020\_3  
 MAT'L: MIŠUMI HFS5-2020  
 QTY 4

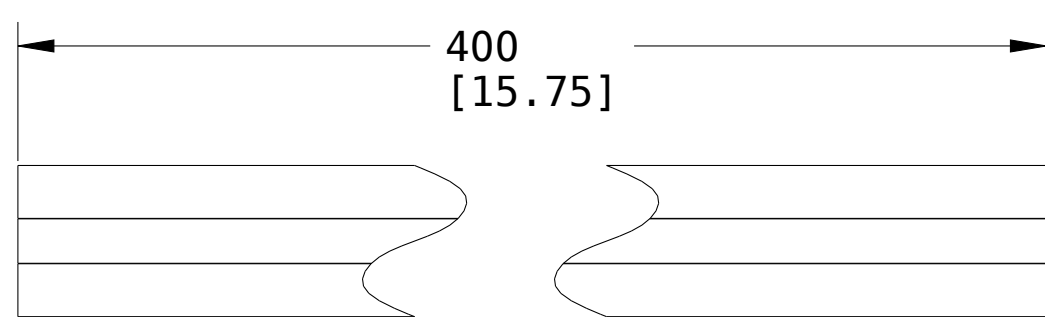
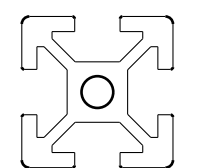

C

EXTR\_2020\_4  
 MAT'L: MIŠUMI HFS5-2020  
 QTY 4

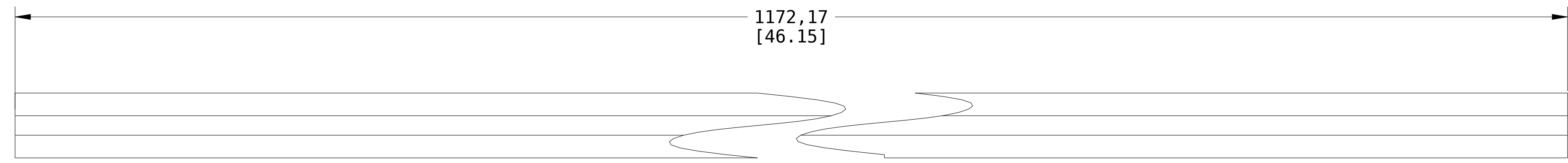
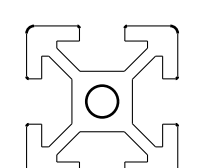

B

EXTR\_2020\_5  
 MAT'L: MIŠUMI HFS5-2020  
 QTY 2

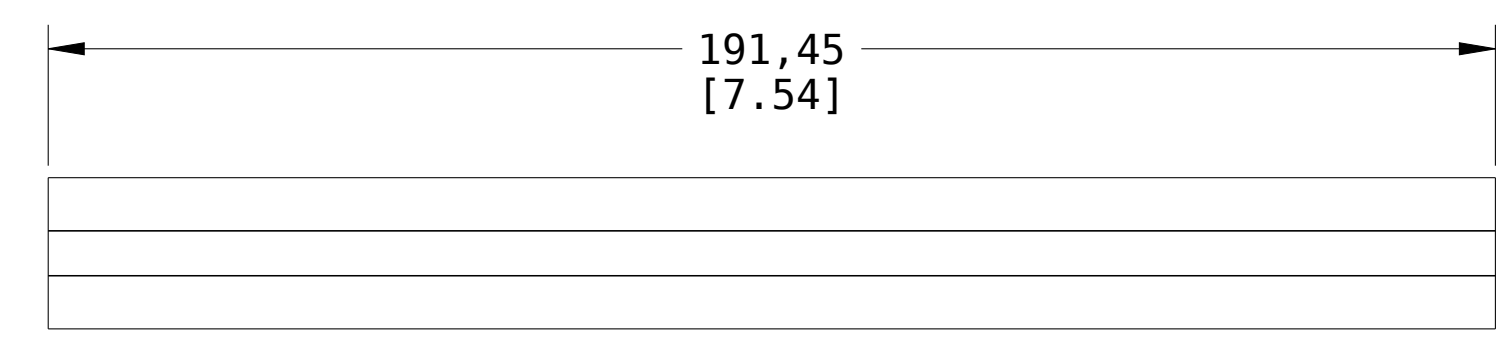
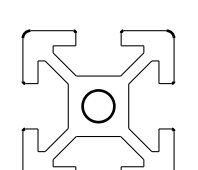

A

EXTR\_2020\_6  
 MAT'L: MIŠUMI HFS5-2020  
 QTY 2

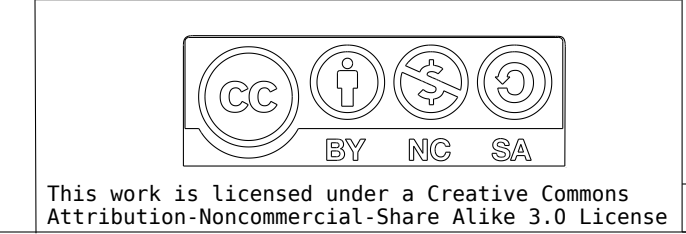
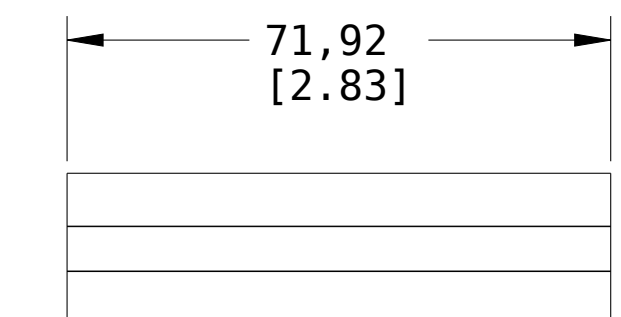
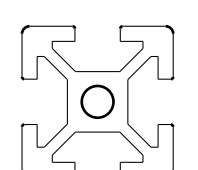

FRAME EXTRUSIONS	 www.buildlog.net
	EXTRUSIONS
SCALE	SHEET 2 OF 4

REVISION	
SYM	DESCRIPTION
6	SEE SHEET 1

F  
E  
D  
C  
B  
A

EXTR\_2020\_COVER\_1  
MAT'L: MISUMI HFS5-2020  
QTY 3

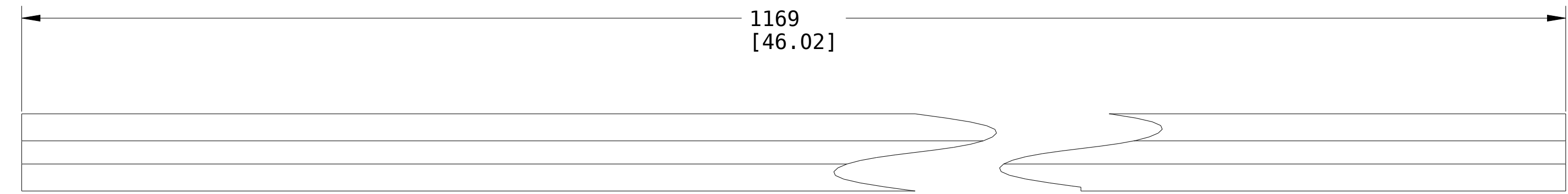
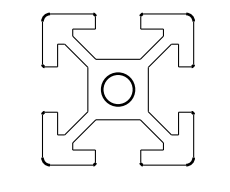

EXTR\_2020\_COVER\_2  
MAT'L: MISUMI HFS5-2020  
QTY 2

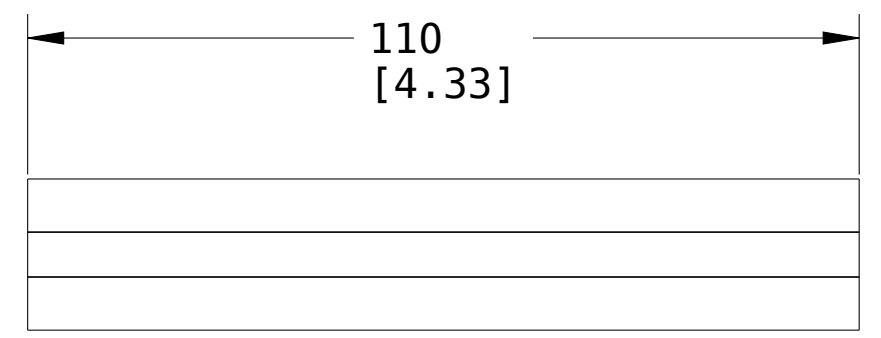
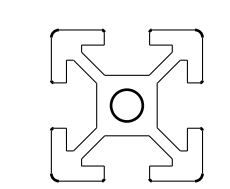

EXTR\_2020\_COVER\_3  
MAT'L: MISUMI HFS5-2020  
QTY 2

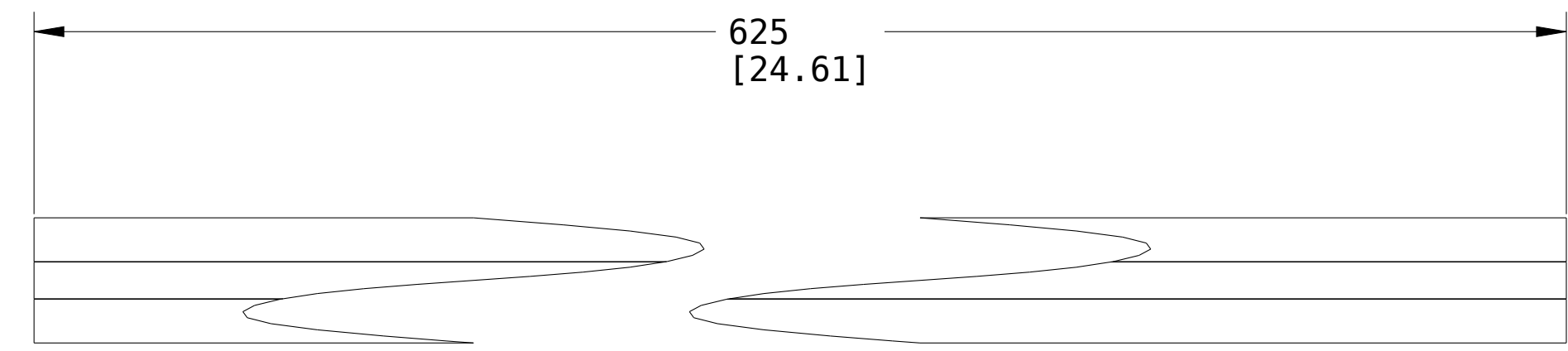
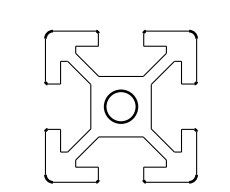

EXTR\_2020\_COVER\_4  
MAT'L: MISUMI HFS5-2020  
QTY 2

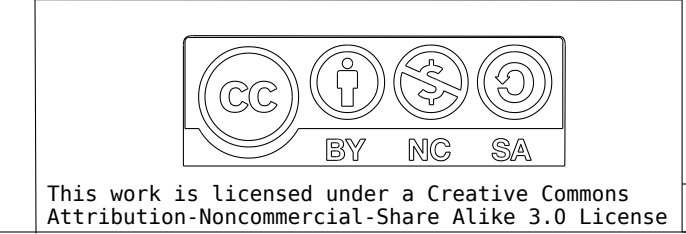
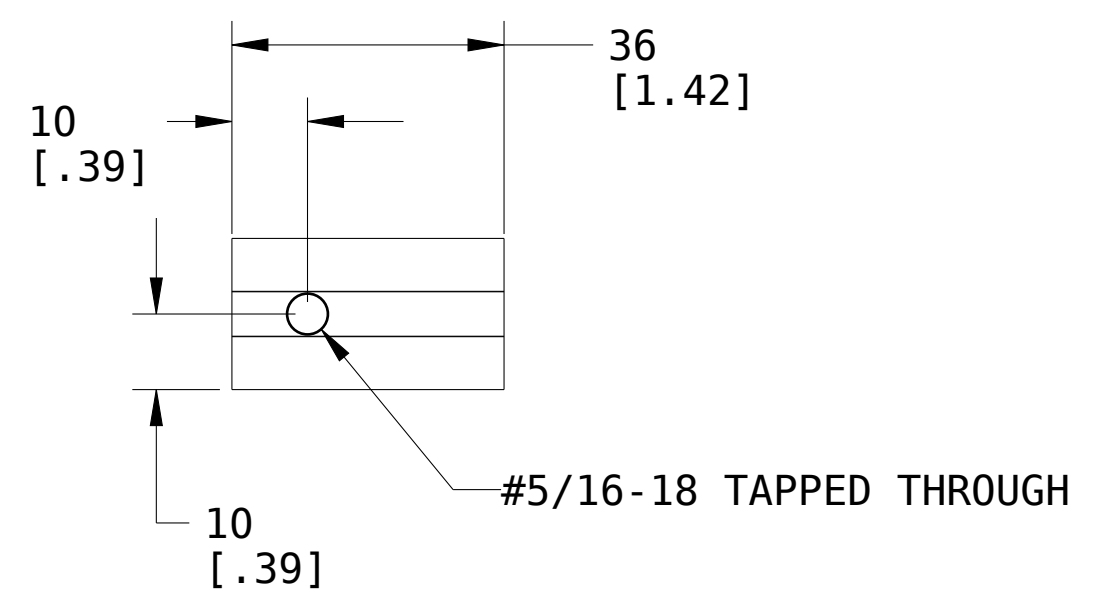
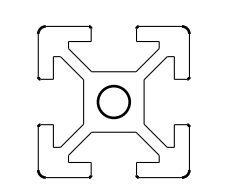

<p><b>COVER EXTRUSIONS</b></p>	 <a href="http://www.buildlog.net">www.buildlog.net</a>
	<p><b>EXTRUSIONS</b></p>
<p>SCALE</p>	<p>SHEET 3 OF 4</p>

1

2

3

4

5

6

7

8

REVISION	
SYM	DESCRIPTION
6	SEE SHEET 1

F

E

EXTR\_2020\_TABLE\_DEPTH  
 MAT'L: MİSUMI HFS5-2020  
 QTY 2

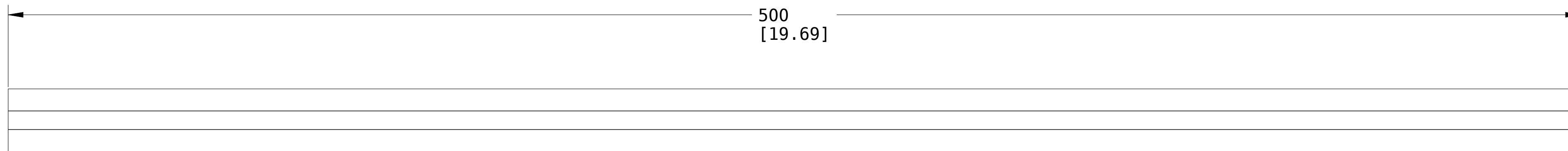
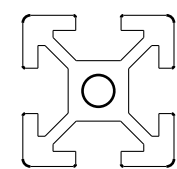

D

EXTR\_2020\_TABLE\_WIDTH  
 MAT'L: MİSUMI HFS5-2020  
 QTY 3

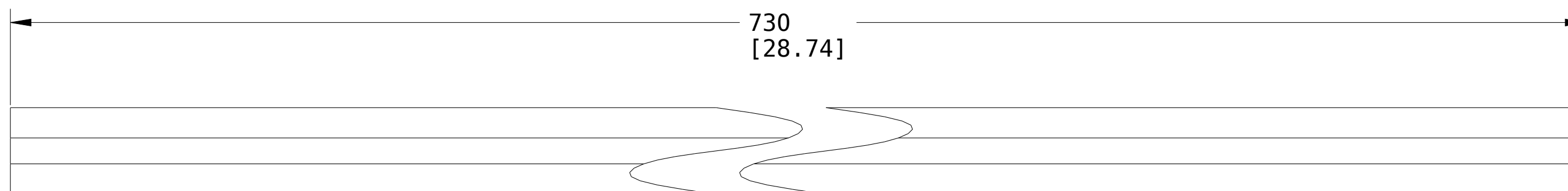
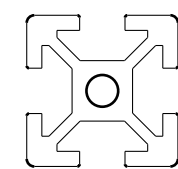

C

B

A

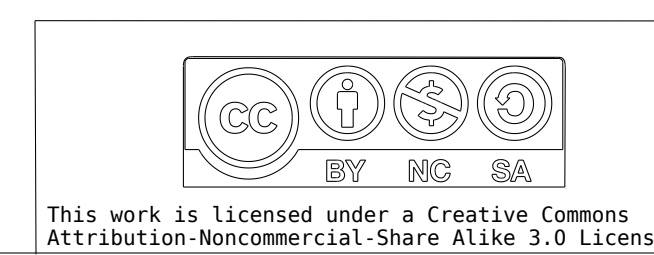

This work is licensed under a Creative Commons Attribution-NonCommercial-Share Alike 3.0 License

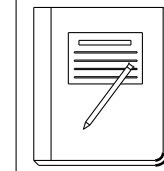
TABLE EXTRUSIONS		 <a href="http://www.buildlog.net">www.buildlog.net</a>
SCALE		
		SHEET 4 OF 4