

REVISIONS				APPROVALS		
SYM	DESCRIPTION	BY	DATE	ENGRG	PROD	Q.A.
1	ORIGINAL	BJD	10/6/09			

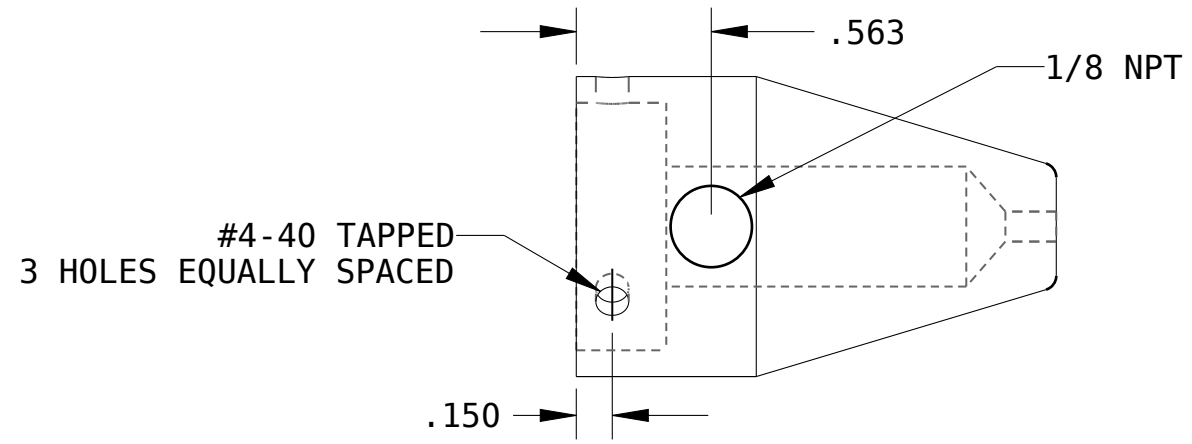
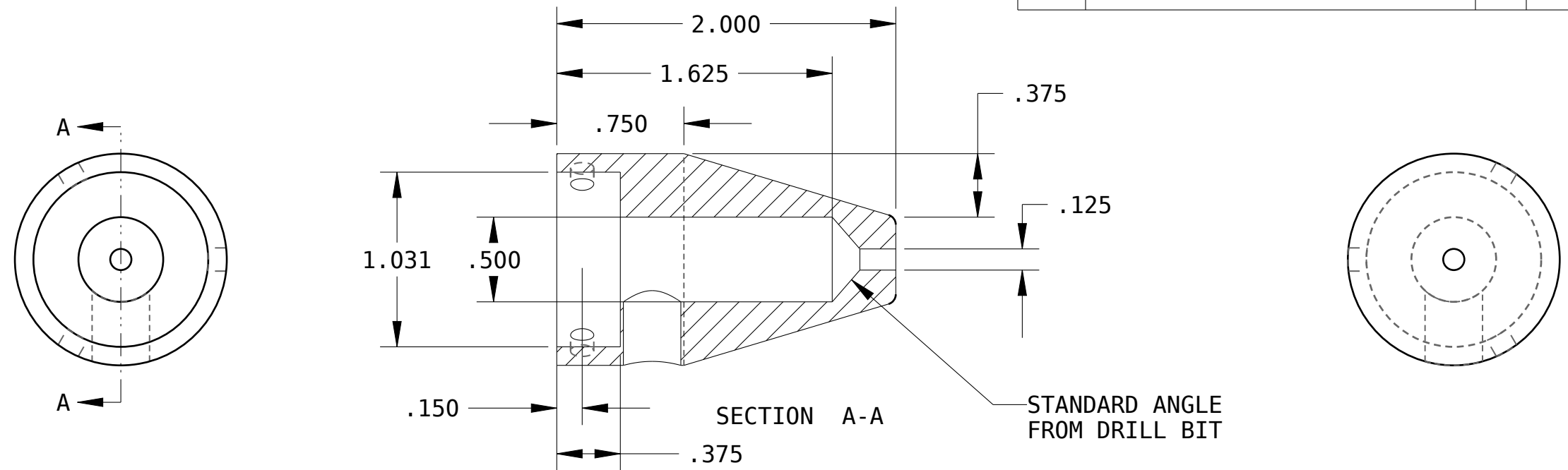

UNLESS OTHERWISE SPECIFIED:		DRAWN	BJD	10/6/09	ASSIST AIR NOOZZLE	NOZZLE
FRACTIONAL	± 1/32	DO NOT SCALE	CHECKER			
DECIMAL	.XXX ± .010		MECH. ENGR.			
	.XX ± .020		ELEC. ENGR.			
ANGULAR	± 1/2°		PROJ. ENGR.			
MATERIAL: ALUMINUM SPEC:		CHIEF ENGR.			SCALE	FSCM NO. 16469
FINISH: SPEC:						SHEET 1 OF 1