

1

2

3

4

5

6

REVISIONS			
SYM	DESCRIPTION	BY	DATE
1	ORIGINAL	BJD	9/10/09
2	REVISED	BJD	2/20/10
3	ADDED DRILL MARKS	BJD	3/11/10
4	Added Sheet 2 for DXF	BJD	10/31/10

D

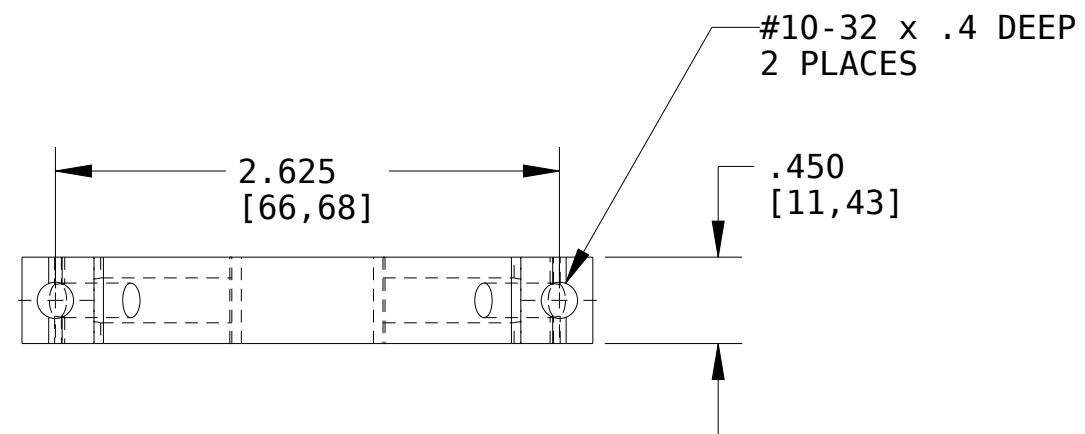

C

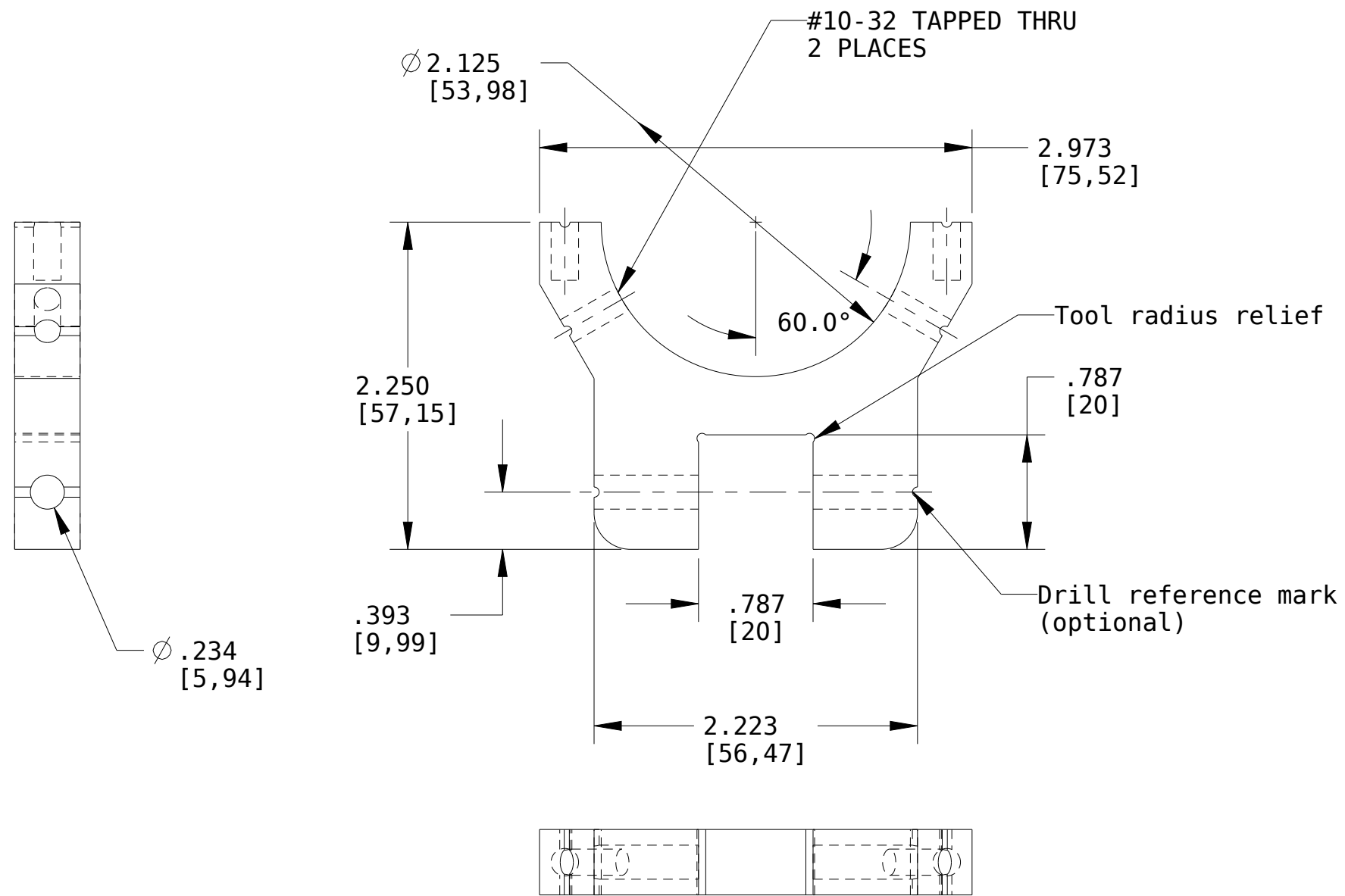

Material: HDPE (White Cutting Board)

B

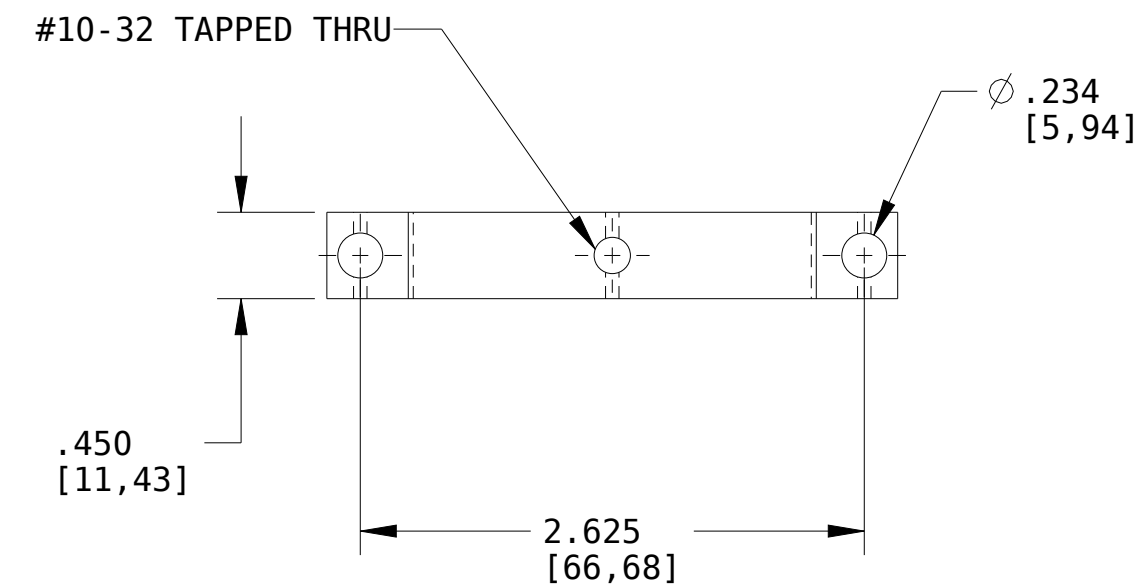
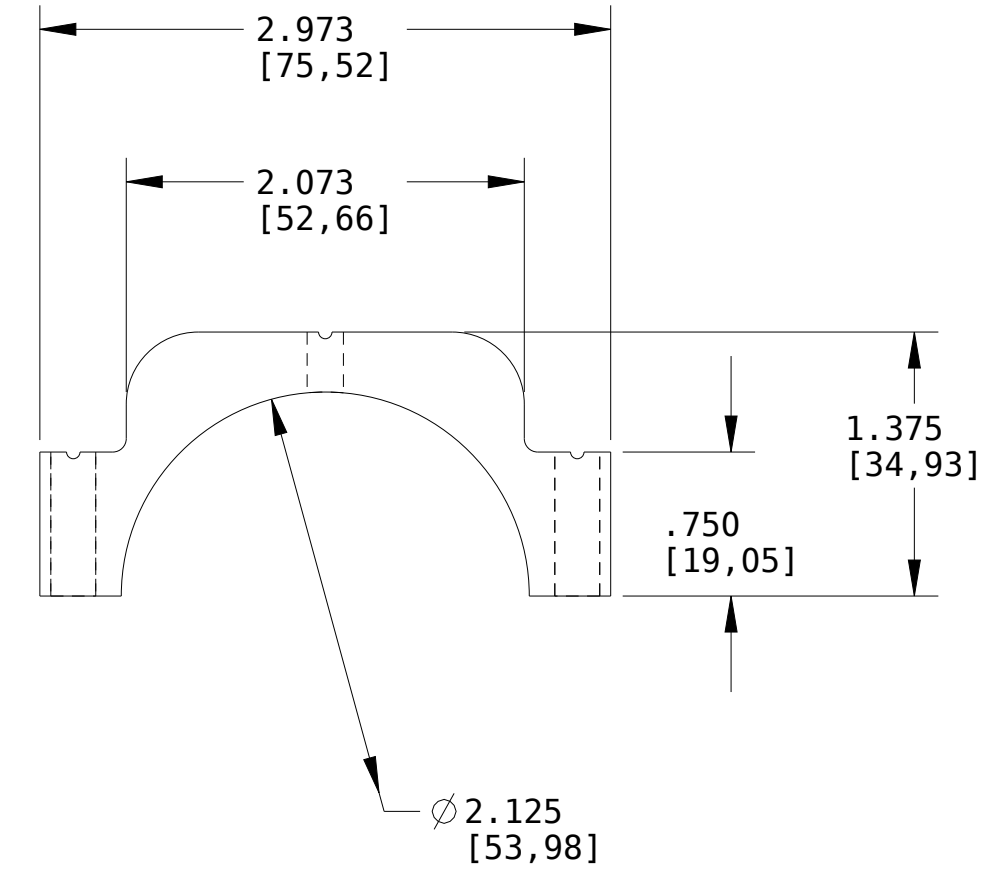

Material: HDPE (White Cutting Board)

A

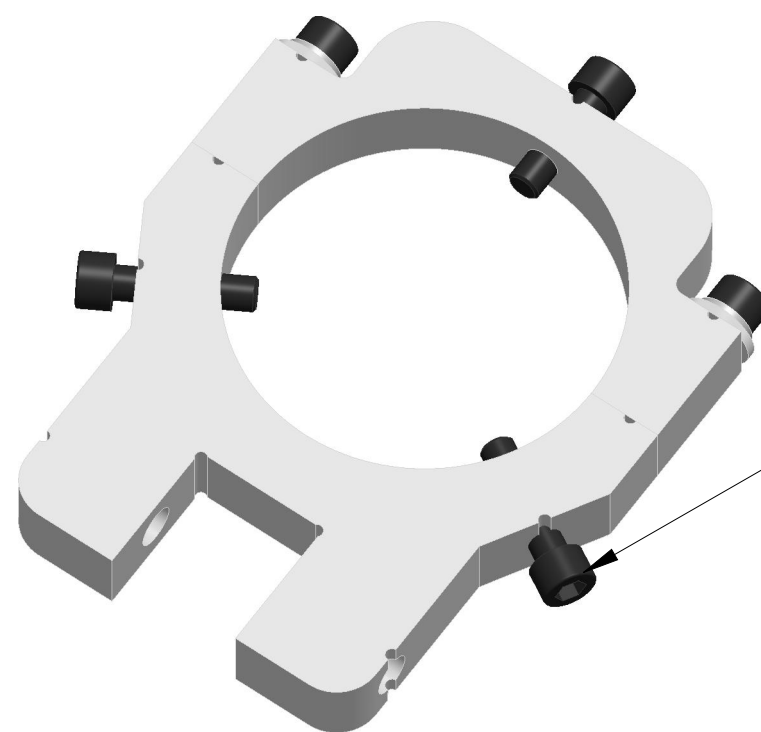

NYLON SCREWS CONTACT TUBE (Gently)



The work is licensed under a Creative Commons Attribution-Share Alike 3.0 License

UNLESS OTHERWISE SPECIFIED:	DRAWN	BJD	9/10/09
FRACTIONAL ± 1/32	DO NOT SCALE	CHECKER	
DECIMAL .XXX ± .010		MECH. ENGR.	
ANGULAR .XX ± .020		ELEC. ENGR.	
FINISH: SPEC:	PROJ. ENGR.		
	CHIEF ENGR.		

TUBE CLAMP



www.buildlog.net

TUBE\_CLAMP

SCALE

SHEET 1 OF 2

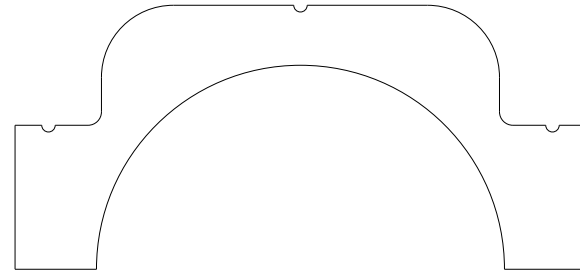
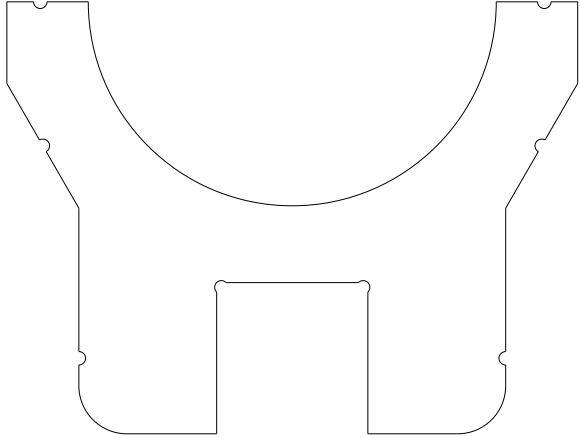

Rev 4 See Sheet 1



[www.buildlog.net](http://www.buildlog.net)

This work is licensed under a Creative Commons Attribution-Noncommercial-Share Alike 3.0 License