

ITEM	SYM	PART NUMBER	QTY	DESCRIPTION
1		CAST CORNER BRACKET	2	MISUMI HBLF5N5
2		CORNER BRACKET	1	MISUMI HBLT5S
3		HNKK55	3	M5 T-SLOT NUT
4		SHMSM510S	3	SOCKET HEAD M5 x 10mm
5		THMS044006S	8	TRUSS HEAD SCREW #4-40 x 3/8
6		V_RAIL_Z_AXIS	2	V RAIL FOR Z AXIS
7		Z_GUIDE_EXTRUSION	1	Z GUIDE EXTRUSION

REVISIONS			
SYM	DESCRIPTION	BY	DATE
1	ORIGINAL	BJD	9/7/10

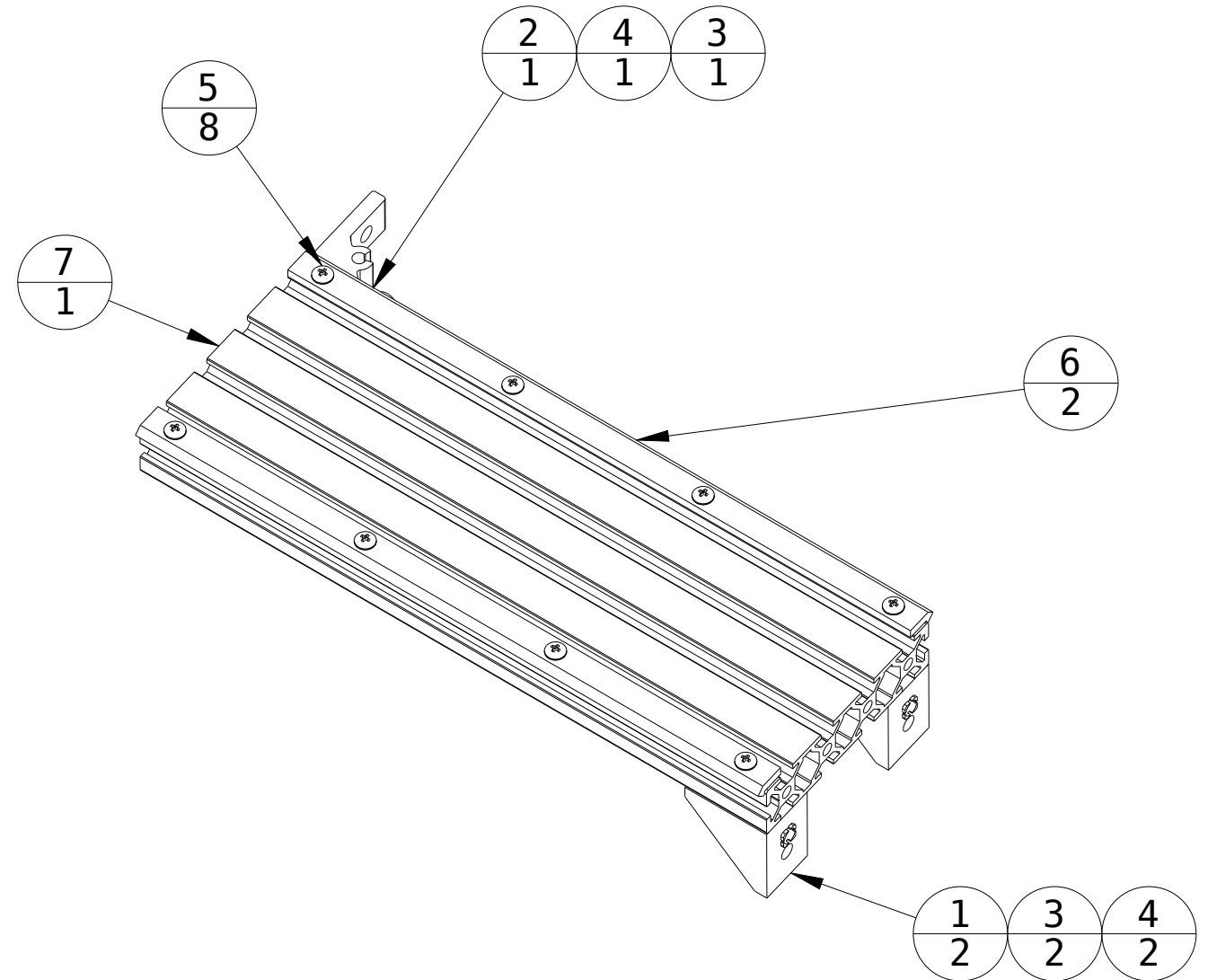
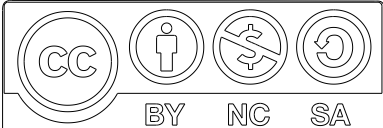
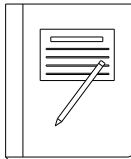

  
 This work is licensed under a Creative Commons Attribution-Noncommercial-Share Alike 3.0 License

UNLESS OTHERWISE SPECIFIED:		DRAWN	BJD	9/7/10	<h2>Z Rail Assembly</h2>	 <a href="http://www.buildlog.net">www.buildlog.net</a> <b>Z_RAIL_ASSEMBLY</b>
FRACTIONAL	± 1/32	CHECKER				
DECIMAL	.XXX ± .010	MECH. ENGR.				
ANGULAR	.XX ± .020	ELEC. ENGR.				
	± 1/2°	PROJ. ENGR.				
MATERIAL: SPEC:		CHIEF ENGR.			SCALE	SHEET 1 OF 1

**DO NOT SCALE**