

REVISIONS			
SYM	DESCRIPTION	BY	DATE
1	ORIGINAL	BJD	1/7/10
2	Minor updates	BJD	11/24/11
3	Add user drilling note	BJD	10/26/12

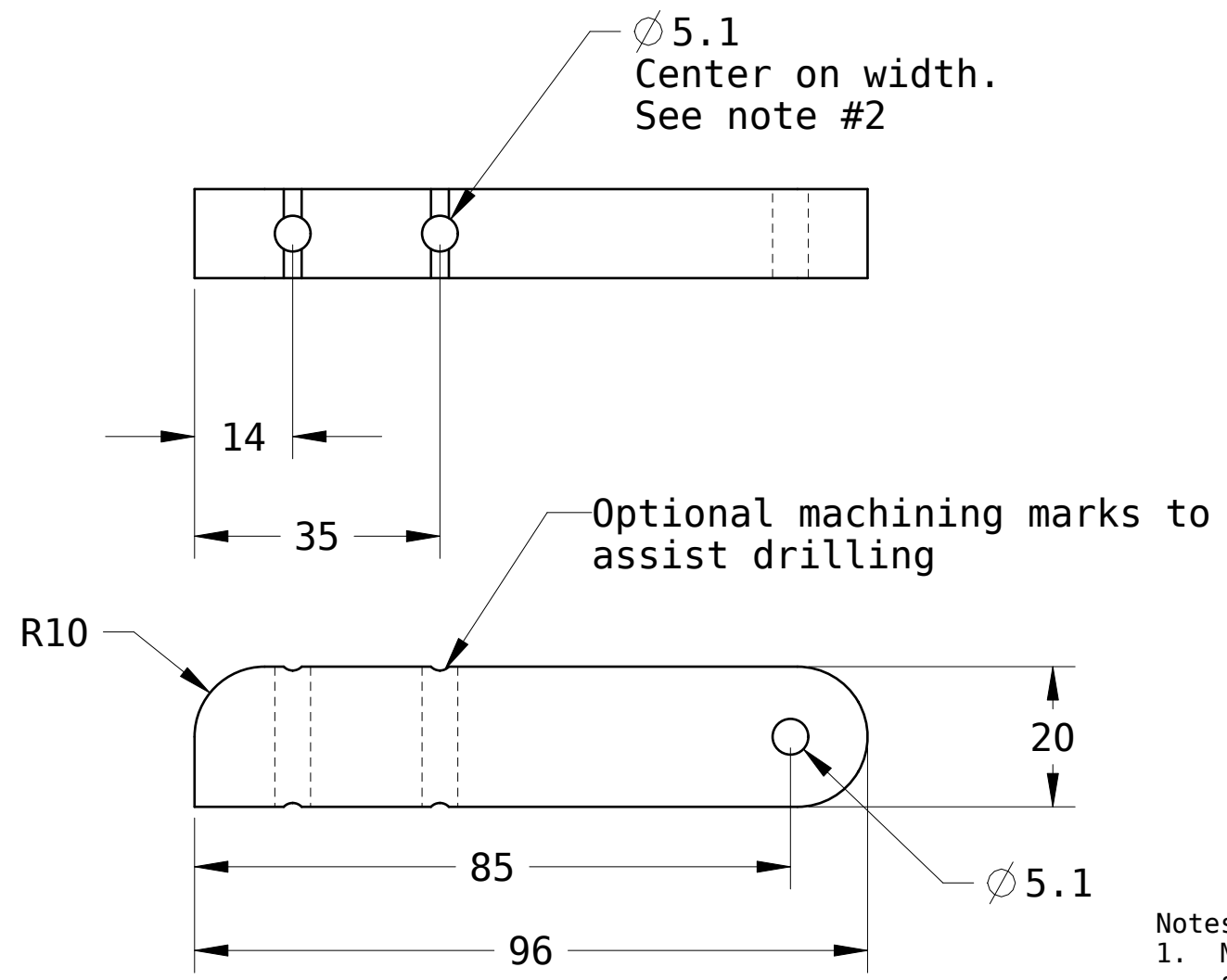

- Notes:
1. Material: HDPE 8.5mm - 18mm acceptable textured or smooth acceptable.
 2. In some kits the (2) holes across the width are not drilled yet. These are to be drilled by the end user. There should be small notches to help locate the drill. The diameter is not critical. It is a clearance hole for a 5mm (0.189") screw.



The work is licensed under a Creative Commons Attribute-Share Alike 3.0 License

DRAWN	BJD	1/7/10
CHECKER		
MECH. ENGR.		
ELEC. ENGR.		
PROJ. ENGR.		
CHIEF ENGR.		

Cover Stop

SCALE



www.buildlog.net

B17011

SHEET 1 OF 1