

REVISIONS			
SYM	DESCRIPTION	BY	DATE
1	ORIGINAL	BJD	4/13/11
2	Change overall width and inner step width	BJD	5/27/11
3	Reduced I.D. for tighter fit	BJD	7/23/12

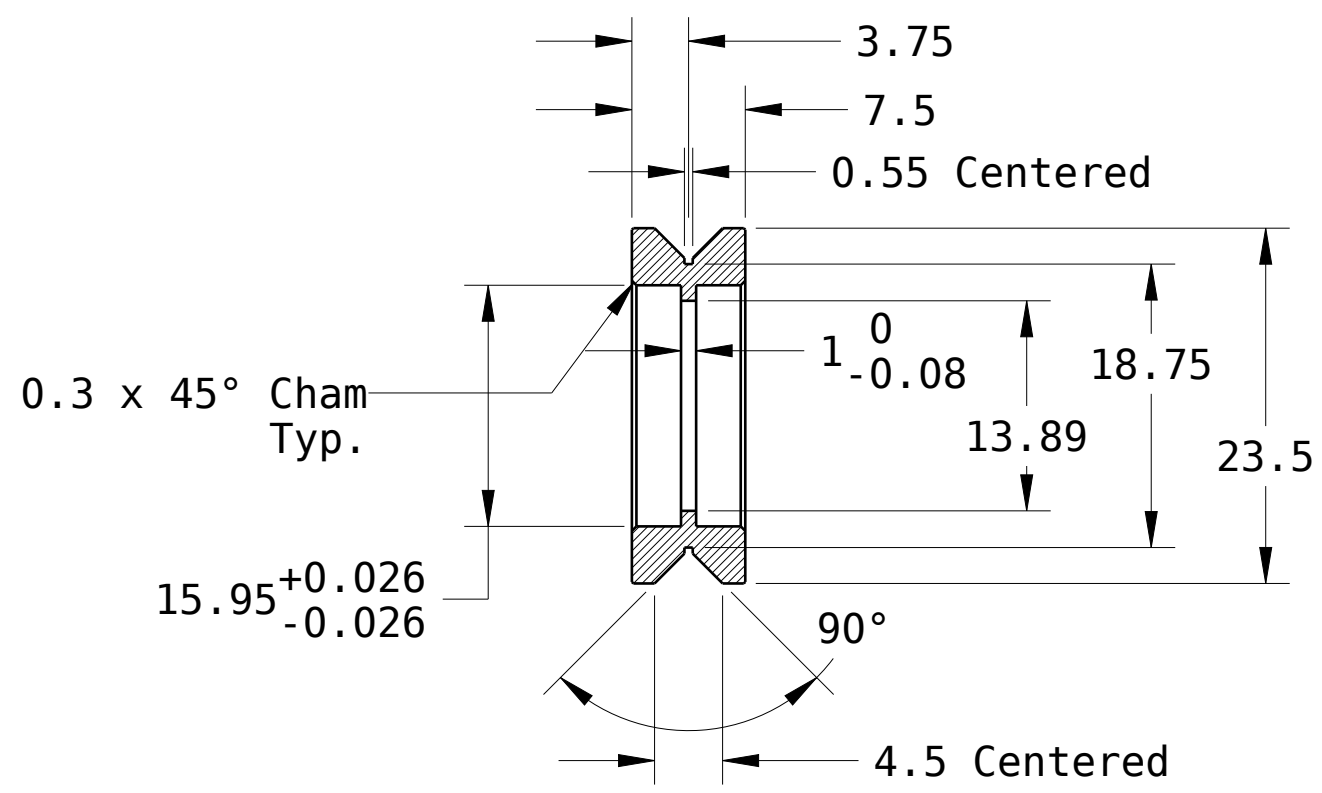

- Notes:
1. All dimensions in millimeters.
 2. Material: Acetal Copolymer (Delrin)
 3. Color: Black

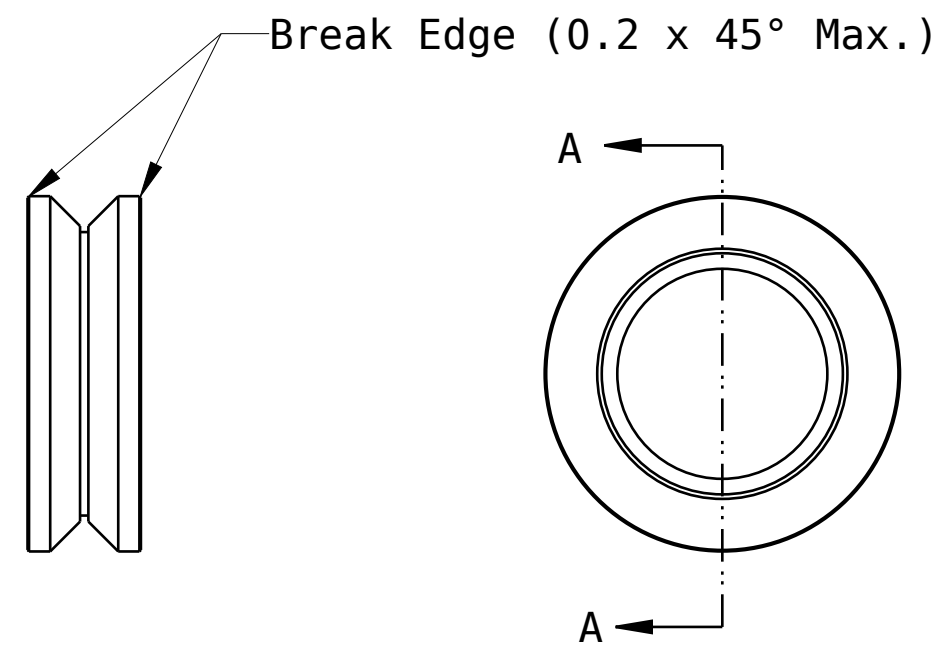

The work is licensed under a Creative Commons Attribution-Share Alike 3.0 License

DRAWN	BJD	4/13/11
CHECKER		
MECH. ENGR.		
ELEC. ENGR.		
PROJ. ENGR.		
CHIEF ENGR.		

Double Bearing
V Wheel

SCALE



www.buildlog.net

B17021

SHEET 1 OF 1