

1

2

3

4

5

6

REVISIONS			
SYM	DESCRIPTION	BY	DATE
1	ORIGINAL	BJD	1/7/10
2	Added alignment step	BJD	2/23/11
3	Clarified holes	BJD	6/27/11
4	Added notch and slots	BJD	10/30/11

Drill Clearance for #10 Screw  
(approx 6mm) 5 Places  
Part has small notches to  
help locate the drill.

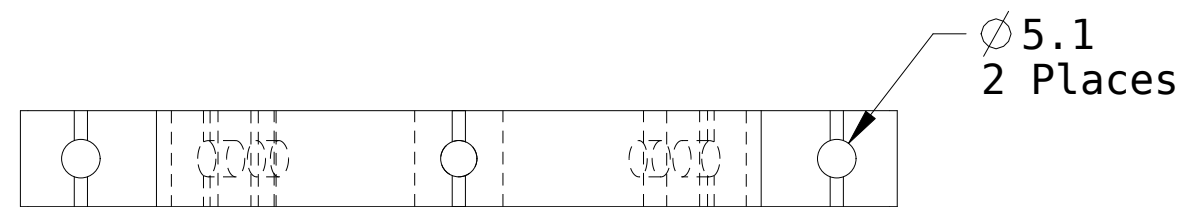
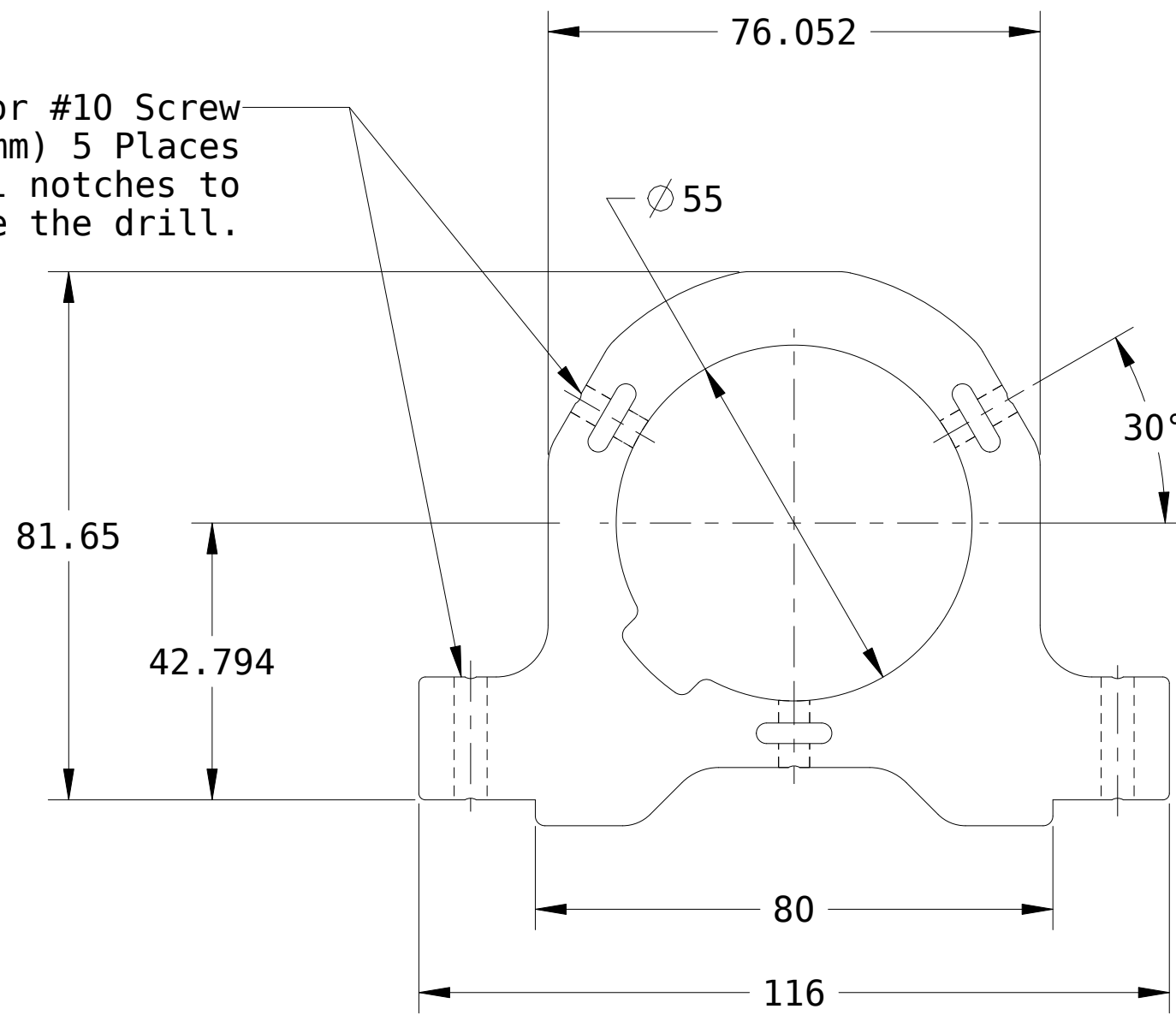

Notes:

1. Material: HDPE 8.5mm - 18mm acceptable textured or smooth acceptable.



The work is licensed under a Creative Commons Attribution-Share Alike 3.0 License

DRAWN	BJD	1/7/10	Tube Support Bracket	
CHECKER				
MECH. ENGR.				C17010
ELEC. ENGR.				SHEET 1 OF 2
PROJ. ENGR.				
CHIEF ENGR.			SCALE	

