

Assembly

Use the BOM section near the end of this document to determine the parts. Be sure to double check the sex of the 9 pin connectors, because either sex will fit in either location.

I find it easiest to assemble the shortest parts first because they can be inserted and the board flipped over and placed on a table. The parts in the pink bags are static sensitive. Use a wrist strap or ground yourself when handling these.

Note the orientation of the U1. The large inductor goes toward the edge of the board. U2 & Q1 will need to have the legs spread slightly.

The jumper headers are sensitive to heat and the pins can melt free of the plastic if you apply too much heat. Sometimes installing the jumper on the pins you solder can help hold it in place.

I use a little dab of super glue to hold the terminal blocks in place while soldering. This makes it easier to solder them straight. Be sure no glue flows onto the solder pads.

Connections

J1

J1 is connects to the laser controller. This controller can be a PC with Mach3 or EMC2 type software or it can be a dedicated microprocessor based laser controller. Some pins have functions like step and direction signals and others are generic inputs and outputs. These are designated by the pin number. Output 14 for example does not mean there are 14 outputs, it means it is an output using pin 14. Unused outputs like Z Step and Z Dir can also be used as generic outputs. The same is true for inputs. The terms input and output on this connector are with respect to the controller, not the interface board.

J1 (Control input connector)	
Pin #	Function (goes to)
1	Output 1 (TB5-6)
2	X Step (TB2 - 1)
3	X Dir (TB2-2)
4	Y Step (TB3-1)
5	Y Dir (TB3-2)
6	Z Step (TB4-1)
7	Z Dir (TB4-2)
8	Output 8 (TB5-5)
9	Output 9 (TB5-4)
10	X Limit Switch Input (J3-9)
11	Y Limit Switch Input (J3-7)
12	Z Limit Switch Input (J3-5)
13	Input 13 (J2-6)
14	Output 14 (TB5-3)
15	Input 15 (J3-3)
16	Motor Enable Output (TB2,3,4-1)
17	Laser On (TB6-1)
18-25	Ground

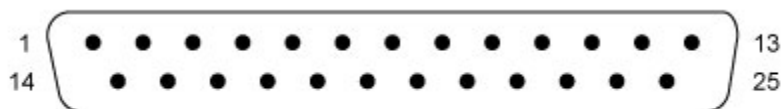

DB-25P (Male Plug Front View)

J2

J2 is intended to connect to a control panel. It provides the basic manual control of the laser, like potentiometer power control and the e stop button. Below is a schematic of a simple control panel.

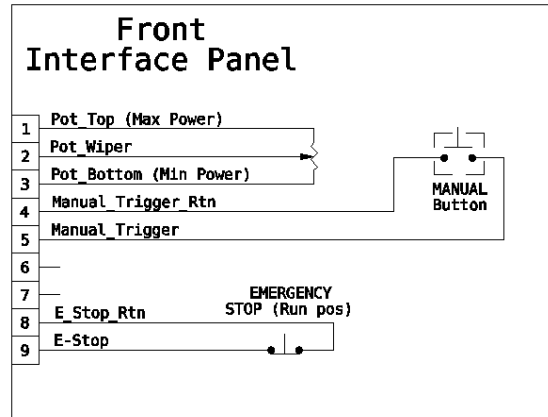

J2 Control Panel Connector - Female	
Pin #	Function
1	Pot Top (Max laser power)
2	Pot Wiper (laser power input)
3	Pot Bottom (Min laser power) (Gnd)
4	Manual Trigger Return (Gnd)
5	Manual Trigger (Goes to enable low)
6	Input 13
7	+5V
8	E-stop Return (laser enable loop)
9	E-Stop (laser enable loop)

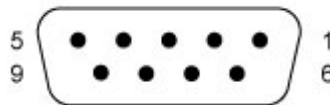

J3

J3 is intended to connect to items inside the enclosure. This would be things like limit switches and cover interlock switches. Below is a simple schematic. There are 10k pull-up resistors on the PCB that pull all inputs to a high state when the circuits open. The high state voltage can either be 5VDC or 3.3VDC depending on jumper JP1. Some controllers run at 3.3VDC and 5VDC would damage them.

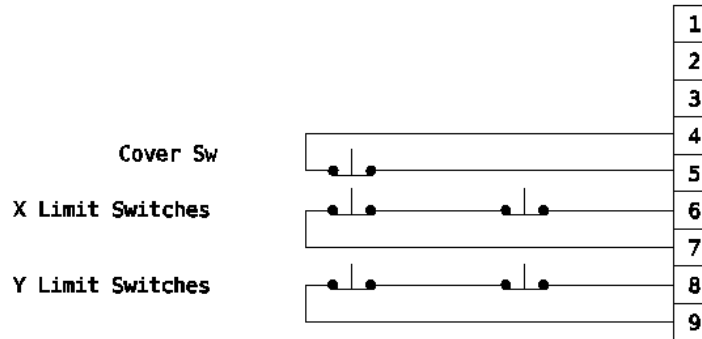

J3 Laser Enclosure Interface - Male	
Pin #	Function
1	Z Limit Switch
2	Input 13
3	Input 15
4	Cover Switch Return
5	Cover Switch
6	X Limit
7	Gnd
8	Y Limit
9	Gnd

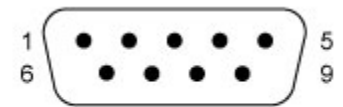

DE-09P (Male Plug Front View)

TB1

TB1 is the main power input for the interface board. This must be at least 7VDC for the internal circuitry. It is recommended that you use the same power supply the powers the steppers drivers. If not, you should make sure you connect this board's ground to the stepper drivers power supplies ground.

TB1 (Power)	
Pin #	
1	Ground
2	7-35V

TB2, TB3 and TB4

TB2, TB3 and TB4 connect to stepper motor drivers. The enable circuit is common for all axes. It is controlled by J1 pin 16. Some laser controllers use a logic level for enable that is different than the stepper driver. Jumper JP2 allows you to select whether J1-16 logic high is an enable or a disable.

TB2 (X Axis), TB3 (Y Axis), TB4 (Z Axis)	
Pin#	Function
1	Step
2	Direction
3	+5V (logic power)
4	Enable (j1-16)

TB5

TB5 breaks out all the output signals. These can be used for controlling relay boards, etc. These are not buffered or isolated. Excessive current or shorting could permanently damage the parallel port or controller attached to these pins. The board is labeled with a lower case "o" to designate output and the corresponding J1 pin number.

TB5 Output Signals	
Pin #	Function
1	Gnd
2	Gnd
3	Output 14
4	Output 9
5	Output 8
6	Output 1

TB6

TB6 Connects to the laser power supply. The pin labeled +5V comes from the laser power supply. It is isolated from other voltages on the PCB. If your laser power supply has a different voltage, that voltage will be present on this circuit. Using this voltage insures the pot references the same voltage for max power.

TB6 Laser Power Supply Interface	
Pin#	Function
1	+5 (From P/S)
2	Input (Power level of laser)
3	Water Pump (Interlock circuit)
4	Gnd
5	Level Low (Gnd to fire laser)
6	Level High (Logic high fires laser)

TB7

TB7 is used to interface to the laser cooling flow circuit. When the appropriate amount of cooling is flowing, the circuit should connect CL to ground. +5V is provided on this terminal block to provide power to more advanced circuits. This circuit assumes your laser power works this way.

TB7 Cooling Interface	
Pin #	Function
1	Gnd
2	+5V
3	CL (connected to ground = good flow)

Bill Of Materials

Designator	Description	Supplier	Supplier P/N
-	Raw Board		
J1	D25P 90Deg .318 Size	Generic	
J2	D9S 90Deg .318 Size	Generic	
J3	D9P 90Deg .318 Size	Generic	
TB1	2 Pos 5mm Terminal block	Generic	
TB2,TB3,TB4	4 Pos 5mm Terminal block	Generic	
TB5, TB6	6 Pos 5mm Terminal Block	Generic	
TB7	3 Pos 5mm Terminal block	Generic	
JP1, JP2	3 Pos .100" Header	Generic	
U1	5V DC-DC P/S	Murata	OKI-78SR-5/1.5-W36-C
U2	3.3V Linear Regulator TO-92	Microchip	MCP1700-3302E
Q1	NPN Transistor TO-92	On Semiconductor	MPS2222
C1	do not place		
C2	do not place		
C3,C4	0.1uF 16V Ceramic Cap	Generic	
R1-R5,R7	10k 1/10W Res	Generic	
R6	1k 1/10W Res	Generic	
CR2	1N4001 Rectifier Diode	Generic	
(4) Spacer	.Nylon Spacer	Generic	
(2) Jumper	.100" Jumper	Generic	

Troubleshooting

The laser will not fire: The entire laser enable loop must be closed. Make sure the e-stop, cover and water pump switches are closed. With power removed, check that TB6-3 is connected to ground

PCB does not product 5V or 3.3V. Check that input voltage and ground are not swapped.

FAQ

Can the outputs drive a relay or LED? No, probably not, they are usually only logic level signals. You should drive a transistor that controls the relay. Make sure you limit the current into the transistor.

Can this connect to a Gecko G540? Yes, you would make a simple cable that had a 25pin connector on one end. The other end would have wires the go to the stepper driver terminal blocks. One wire should go to one of the ground pins on the 25 pin connector (18-25) to a ground point on the interface board, such as TB5 1 or 2. You can connect one of the stepper driver's motor enable to

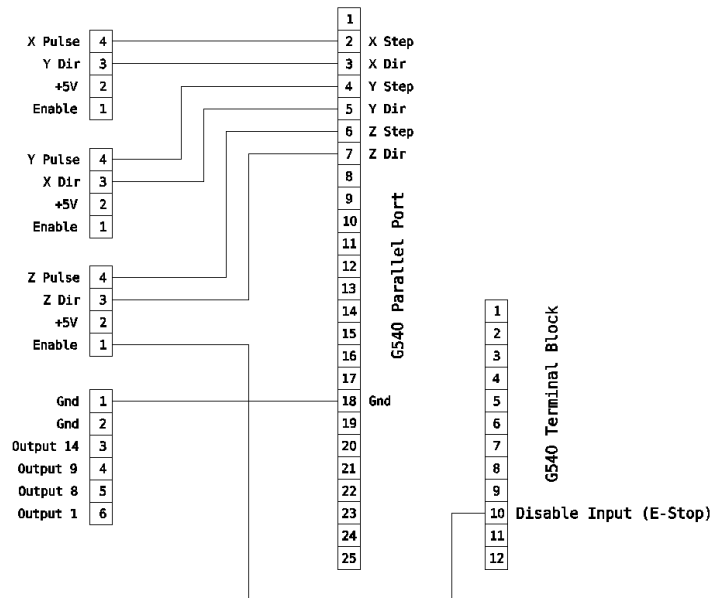

Rev History

Rev 1: Initial Release

Rev 2 Fixed Footprints, Added CR2 (reverse voltage protection)

Test Procedure

1. Visually inspect all solder joints.
2. Setup a bench power supply for 24VDC and current limited to 0.10 amps.
3. Connect the ground side of a DVM to TB5 pin #1 (labeled GND)
4. With power supply off, connect power to TB1.
5. Apply power. If DUT draws more than 0.01amp reject. Debug and repair.
6. Verify power supplies.
 - a. **Measure 3.3VDC at JP1.** Record in data section.
 - b. **Measure 5VDC at JP1.** Record in data section.
7. Turn off 24VDC power supply
8. Verify enable circuit.
 - . Place JP2 enable/disable jumper on disable side.
 - a. Connect + side of DVM to TB4 Pin #1 (Marked ENB)
 - b. Connect pin #16 of J1 to ground
 - c. Turn on 24VDC power supply.
 - d. **Record DVM voltage.** Record in data section.
 - e. Connect pin #16 of J1 to 5VDC
 - f. **Record DVM voltage.** Record in data section.
 - g. Turn off power supply.
 - h. Move jumper to enable side.
 - i. Turn on 24VDC power supply
 - j. **Record DVM voltage.** Record in data section.
 - k. Turn of 24VDC power supply.
 - l. Connect pin #16 of J1 to ground
 - m. Turn on 24VDC
 - n. **Record DVM voltage.** Record in data section.
 - o. Turn off power supply
9. Place Jumpers in default locations (5V & Enable)

Data Section				
Step	Description	Data	Units	Pass Criteria
1	Visual Inspection	<input type="checkbox"/>	-----	checked
6a	3.3V Power Supply		Volts	3.28 – 3.33
6b	5.0V Power Supply		Volts	4.85 – 5.15
8d	Disable mode connected to Gnd		Volts	Logic high
8f	Disable mode connected to 5V		Volts	Logic low
8j	Enable mode connected to 5V		Volts	Logic high
8n	Enable mode connected to Gnd		Volts	Logic low
9	Place Jumpers	<input type="checkbox"/>	-----	checked
Tested By			Date	

