

1 2 3 4 5 6 7 8

REVISIONS				APPROVALS		
SYM	DESCRIPTION	BY	DATE	ENGRG	PROD	Q.A.
1	ORIGINAL	BJD	8/14/09			
2	UPDATED BOTTOM SKIN	BJD	1/4/10			

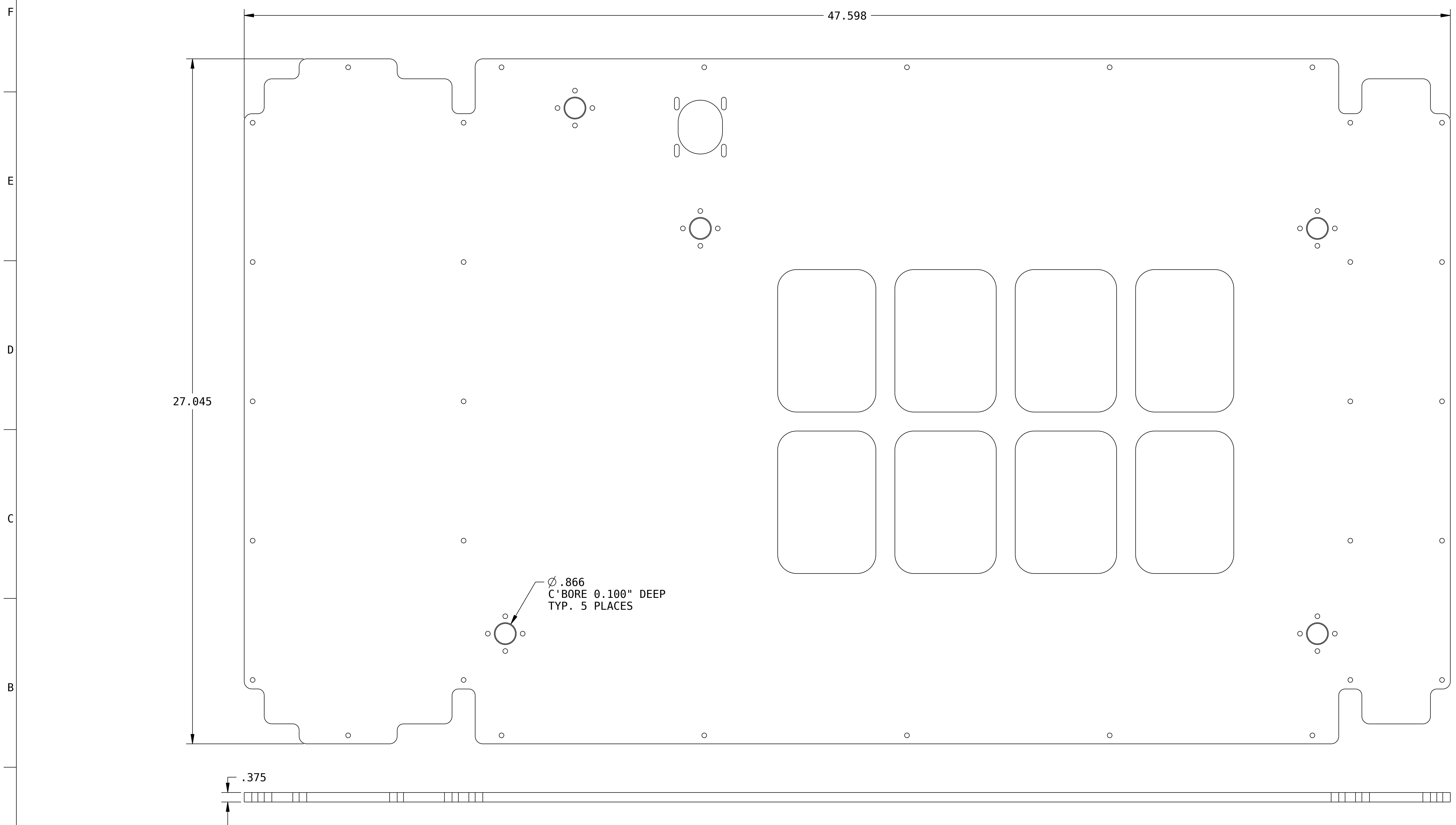

.375

UNLESS OTHERWISE SPECIFIED:		DRAWN	BJD	8/14/09	FLOOR OF ENCLOSURE	
FRACTIONAL ± 1/32	DECIMAL .XXX ± .010	DO NOT SCALE		CHECKER		
ANGULAR .XX ± .020	± 1/2°			MECH. ENGR.	ENCLOSURE_SKINS	
MATERIAL:				ELEC. ENGR.		
SPEC:				PROJ. ENGR.		
FINISH:				CHIEF ENGR.	SCALE	FSCM NO. 16469
SPEC:						SHEET 1 OF 6

1 2 3 4 5 6 7 8

REVISION	
SYM	DESCRIPTION
2	SEE SHEET 1

F
E
D
C
B
A

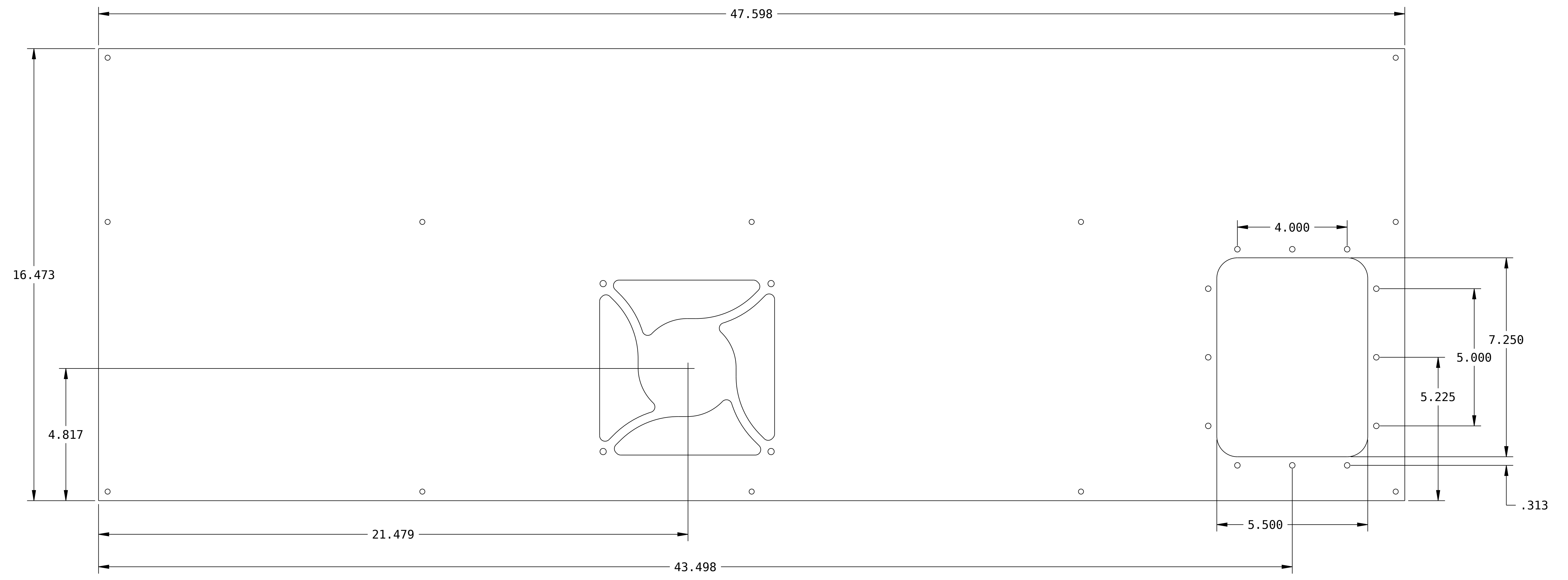

PROPRIETARY INFORMATION
 THIS DOCUMENT CONTAINS PROPRIETARY INFORMATION WHICH SHALL NOT BE REPRODUCED, TRANSFERRED TO OTHER DOCUMENTS, DISCLOSED TO OTHERS, USED FOR MANUFACTURING OR ANY OTHER PURPOSE WITHOUT PRIOR WRITTEN PERMISSION FROM MCL, INC.

BACK OF ENCLOSURE

SCALE

FSCM NO. 16469

630-759-0598
 501 S. WOODCREEK RD
 BOLLINGBROOK, IL 60440-4999

ENCLOSURE_SKINS

SHEET 2 OF 6

1

2

3

4

5

6

7

8

F

E

D

C

B

A

REVISION	
SYM	DESCRIPTION
2	SEE SHEET 1



PROPRIETARY INFORMATION
 THIS DOCUMENT CONTAINS PROPRIETARY INFORMATION WHICH SHALL NOT BE REPRODUCED, TRANSFERRED TO OTHER DOCUMENTS, DISCLOSED TO OTHERS, USED FOR MANUFACTURING OR ANY OTHER PURPOSE WITHOUT PRIOR WRITTEN PERMISSION FROM MCL, INC.

FRONT OF ENCLOSURE

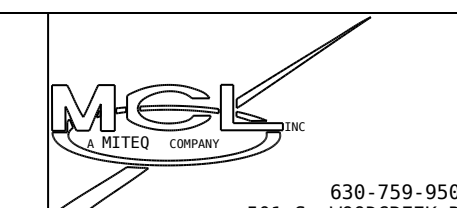

ENCLOSURE_SKINS

630-759-0598
 501 S. WOODCREEK RD
 BOLINGBROOK, IL 60440-4999

SCALE

FSCM NO. 16469

SHEET 3 OF 6

1 2 3 4 5 6 7 8

REVISION	
SYM	DESCRIPTION
2	SEE SHEET 1

F

27.045

.000

47.598

E

20.250

D

C

B

.000

7.799

44.849

A

PROPRIETARY INFORMATION
 THIS DOCUMENT CONTAINS PROPRIETARY INFORMATION WHICH SHALL NOT BE REPRODUCED, TRANSFERRED TO OTHER DOCUMENTS, DISCLOSED TO OTHERS, USED FOR MANUFACTURING OR ANY OTHER PURPOSE WITHOUT PRIOR WRITTEN PERMISSION FROM MCL, INC.

ENCLOSURE TOP

SCALE FSCM NO. 16469

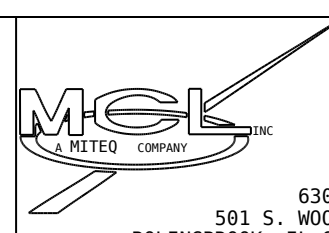

630-759-0598
 501 S. WOODCREEK RD
 BOLINGBROOK, IL 60440-4999

ENCLOSURE_SKINS

SHEET 4 OF 6

1 2 3 4 5 6 7 8

REVISION	
SYM	DESCRIPTION
2	SEE SHEET 1

F

E

D

C

B

A

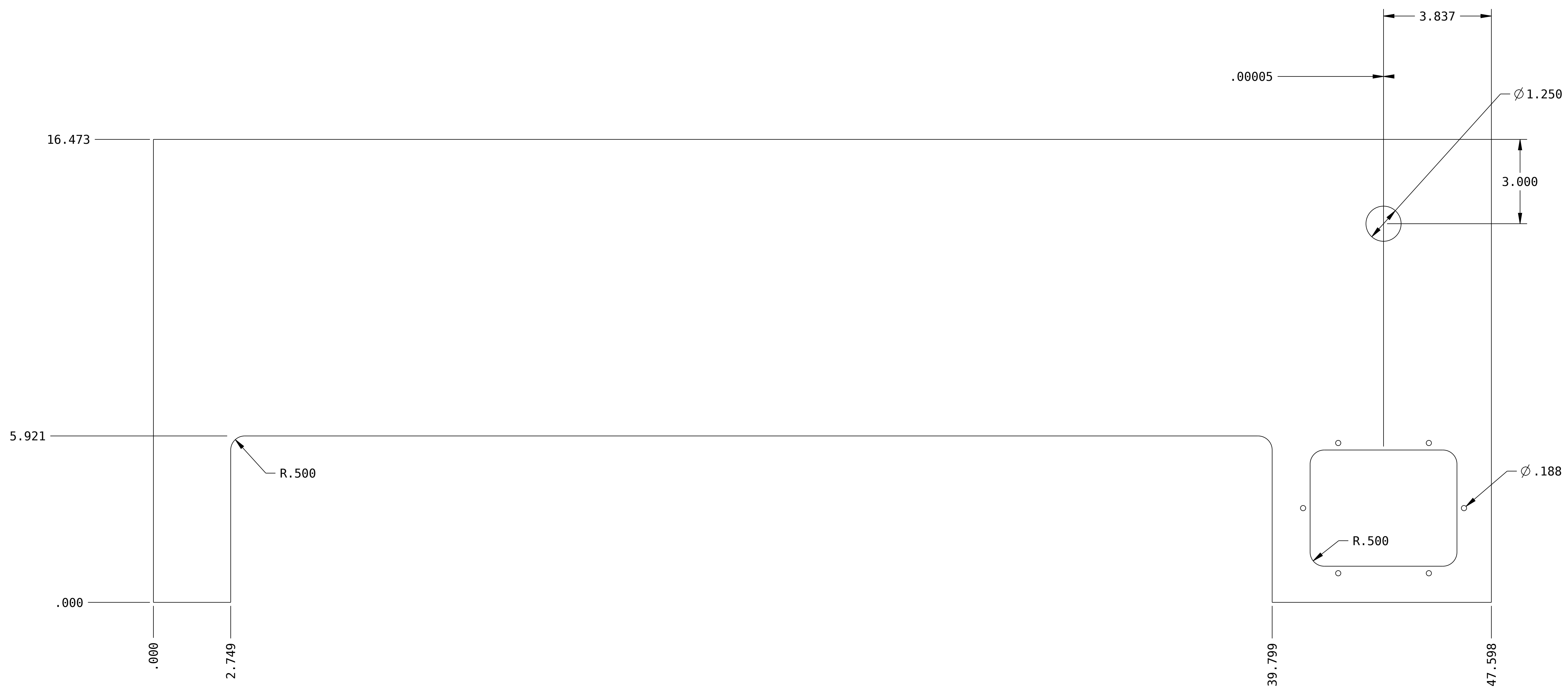

PROPRIETARY INFORMATION
 THIS DOCUMENT CONTAINS PROPRIETARY INFORMATION WHICH SHALL NOT BE REPRODUCED, TRANSFERRED TO OTHER DOCUMENTS, DISCLOSED TO OTHERS, USED FOR MANUFACTURING OR ANY OTHER PURPOSE WITHOUT PRIOR WRITTEN PERMISSION FROM MCL, INC.

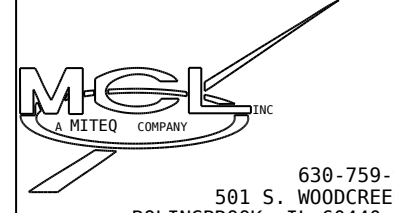
SKIN_TOP	 630-759-0588 501 S. WOODCREEK RD BOLINGBROOK, IL 60440-4999
SCALE	FSCM NO. 16469
SHEET 5 OF 6	

REVISION	
SYM	DESCRIPTION
2	SEE SHEET 1

F

E

D

C

B

A

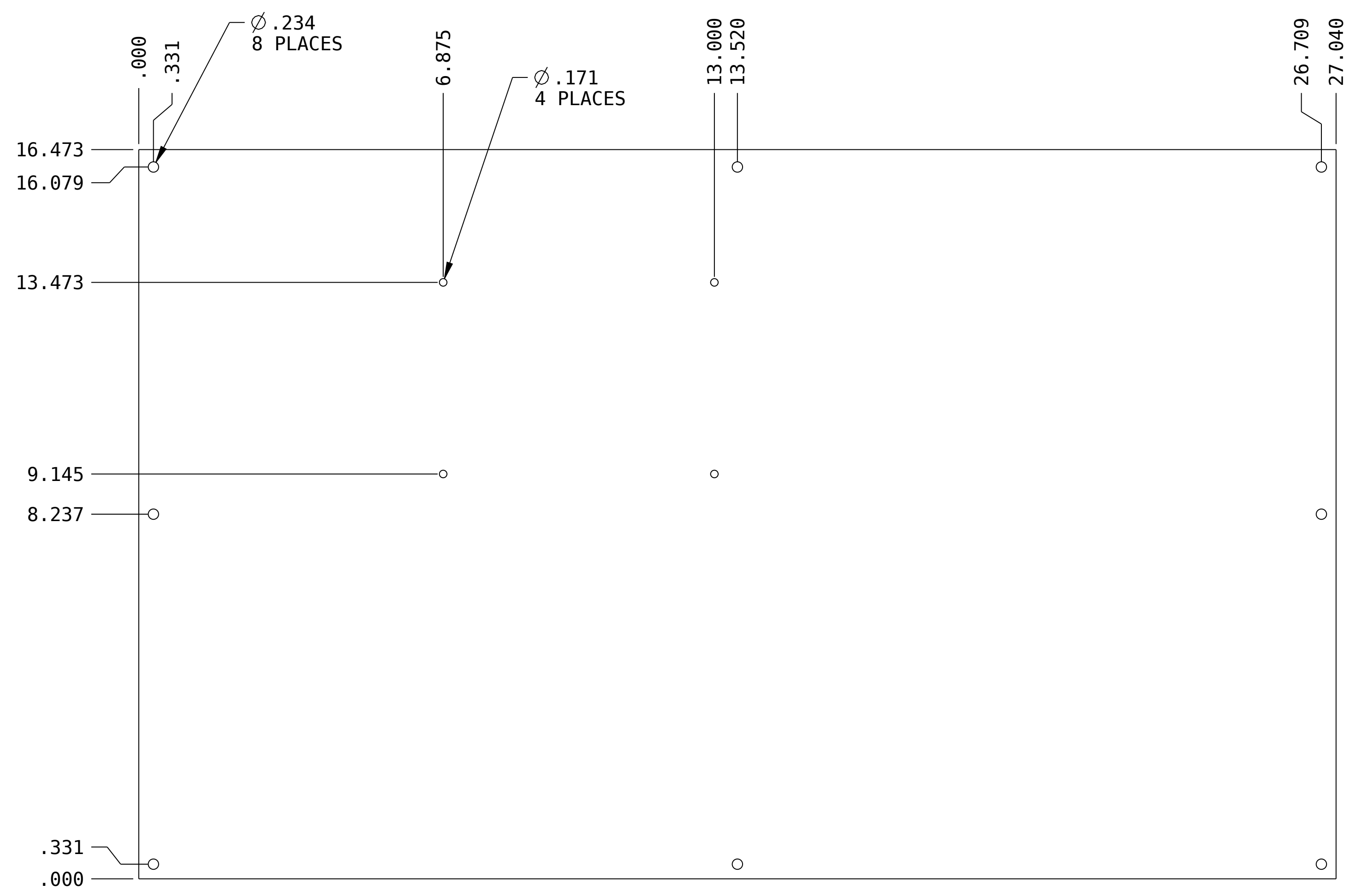

PROPRIETARY INFORMATION
 THIS DOCUMENT CONTAINS PROPRIETARY INFORMATION WHICH SHALL NOT BE REPRODUCED, TRANSFERRED TO OTHER DOCUMENTS, DISCLOSED TO OTHERS, USED FOR MANUFACTURING OR ANY OTHER PURPOSE WITHOUT PRIOR WRITTEN PERMISSION FROM MCL, INC.

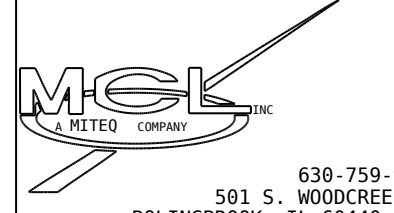
<p>LEFT SIDE OF ENCLOSURE</p>	
	<p>ENCLOSURE_SKINS</p>
<p>SCALE</p>	<p>FSCM NO. 16469</p>
<p>SHEET 6 OF 6</p>	

630-759-0598
 501 S. WOODCREEK RD
 BOLINGBROOK, IL 60440-4999