

1

2

3

4

5

6

REVISIONS				APPROVALS		
SYM	DESCRIPTION	BY	DATE	ENGRG	PROD	Q.A.
1	ORIGINAL	BJD	9/10/09			

D
C
B
A

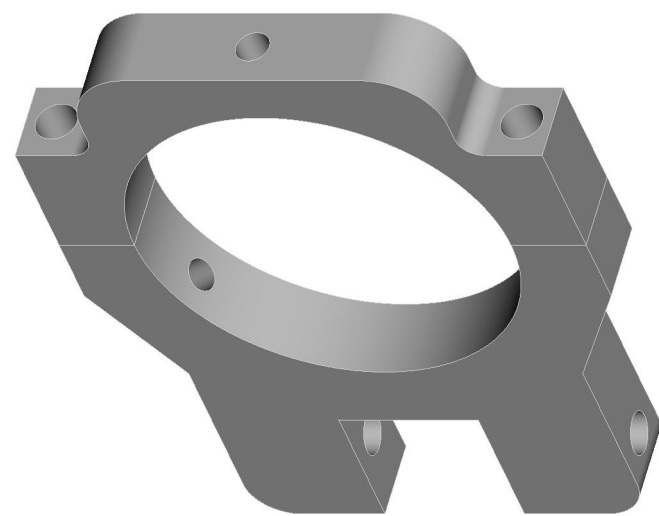
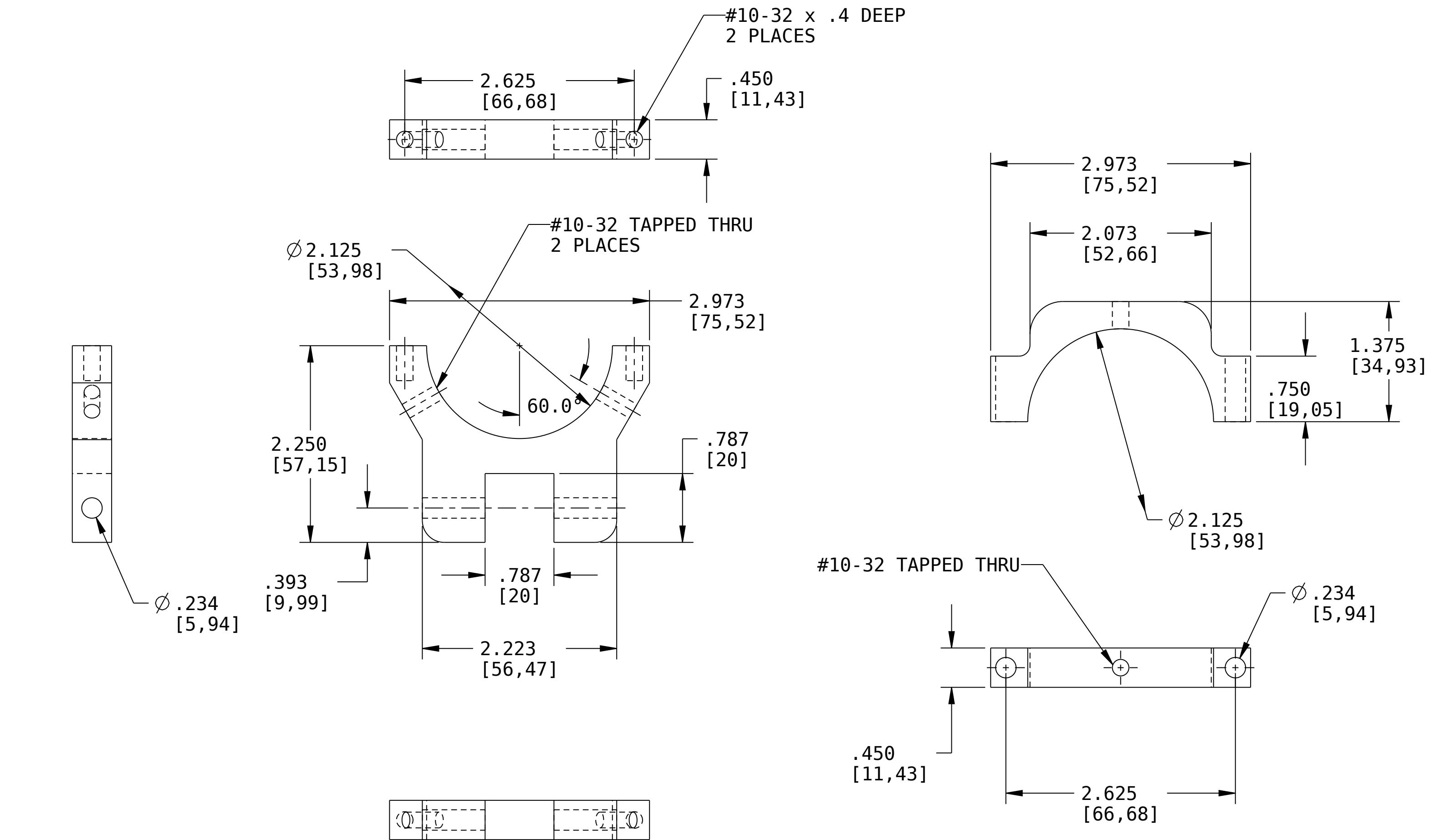

UNLESS OTHERWISE SPECIFIED:	DRAWN	BJD	9/10/09	TUBE CLAMP	
FRACTIONAL ± 1/32	DO NOT SCALE	CHECKER			
DECIMAL .XXX ± .010		MECH. ENGR.			
.XX ± .020		ELEC. ENGR.			
ANGULAR ± 1/2°		PROJ. ENGR.			
MATERIAL: SPEC:		CHIEF ENGR.			
FINISH: SPEC:				SCALE	SHEET 1 OF 1