

ITEM	SYM	PART NUMBER	QTY	DESCRIPTION
1		A 6A 3-12DF02508	1	TIMING PULLY .2 PITCH 12 TOOTH
2		A 6R 3-245025	1	TIMING BELT 245 TOOTH
3		bearing_8_22_7	2	BEARING 8mm 22mm 7mm
4		CABLE_GUIDE_BRACKET	1	CABLE GUIDE SUPPORT BRACKET
5		GANTRY	1	GANTRY ASSEMBLY
6		IDLER_BRKT	1	IDLER PULLER BRACKET
7		NEMA_23	1	STEPPER MOTOR NEMA 23
8		PHOTO_INT	2	PHOTO INTERRUPTOR
9		WASHER_FENDER_312	1	FENDER WASHER
10		Y_AXIS	2	Y AXIS BEAM ASSY
11		Y_AXIS_MOTOR_BRKT	1	Y AXIS MOTOR BRACKET

REVISIONS				APPROVALS		
SYM	DESCRIPTION	BY	DATE	ENGRG	PROD	Q.A.
1	ORIGINAL	BJD	7/4/09			
2	UPDATED	BJD	7/6/09			
3	UPDATED	BJD	9/6/09			

F
E
D
C
B
A

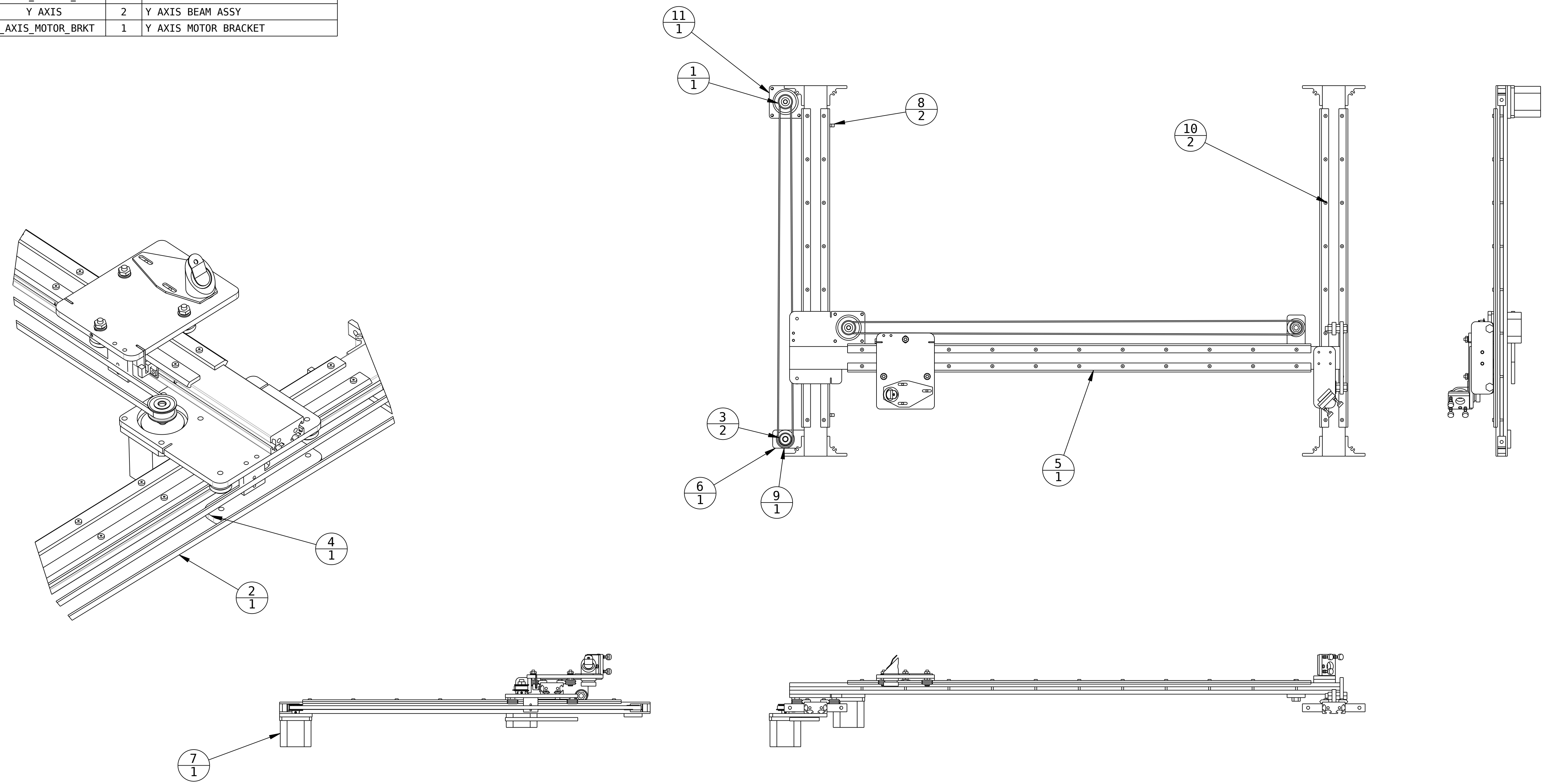

UNLESS OTHERWISE SPECIFIED:		DRAWN	BJD	7/4/09	XY MECHANISM ASSY	XY ASSEMBLY
FRACTIONAL	± 1/32	DO NOT SCALE	CHECKER			
DECIMAL	± .010		MECH. ENGR.			
ANGULAR	± 1/2°		ELEC. ENGR.			
MATERIAL SPEC:		PROJ. ENGR.				
FINISH SPEC:		CHIEF ENGR.				
SCALE		FSCM NO. 16469		SHEET 1 OF 1		