

80 Watt CO2 Power Supply

Model: JLD-SZCO80W

Introduction

This power supply is designed for 80Watt CO2 Laser products with wavelength from 800-10600nm. It's suitable for the laser applying in engraving, cutting or medication equipment. Power is controllable from TTL (20KHz or an analog signal 0-5V). Output is controllable in the of continually or in pulse.

Specification

Model		JLD-SZCO80W
Input	Volt	AC 110~220V +/- 10%
	Current	28A
Output	Triggering Voltage	30KV
	Operating Voltage	20KV
	Current Adjustment	0-26mA
	Control Input	0-5V TTL 10mA
	Min. Pulse width	1mS
	Output current	0.5mA
	Temperature	-10 to 45°C
	Storage Temp	-25 to 75°C
	Size	350* 230* 110 mm
	Weight	5Kg

Basic Connection Diagram

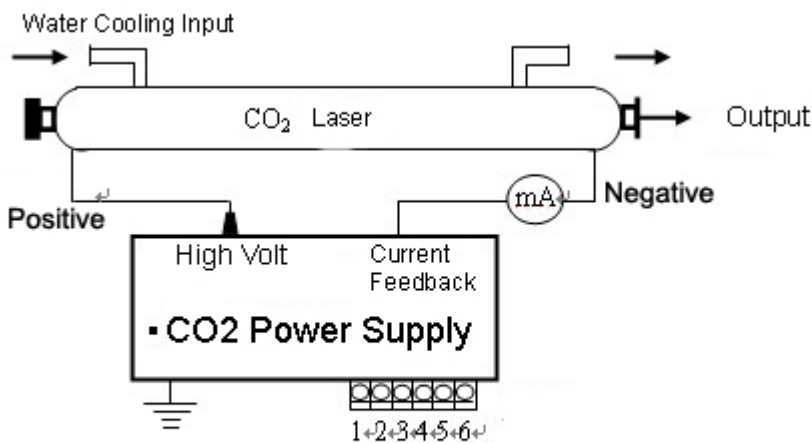

Terminals & Configuration

1	2	3	4	5	6
TH	TL	WP	G	IN	5V
Level High	Level Low	Water Pump	Ground	Input	+5V DC

The power is controllable from TTL and/or by an analog signal of 0-5V through a 5K~10K variable resistor. See picture below

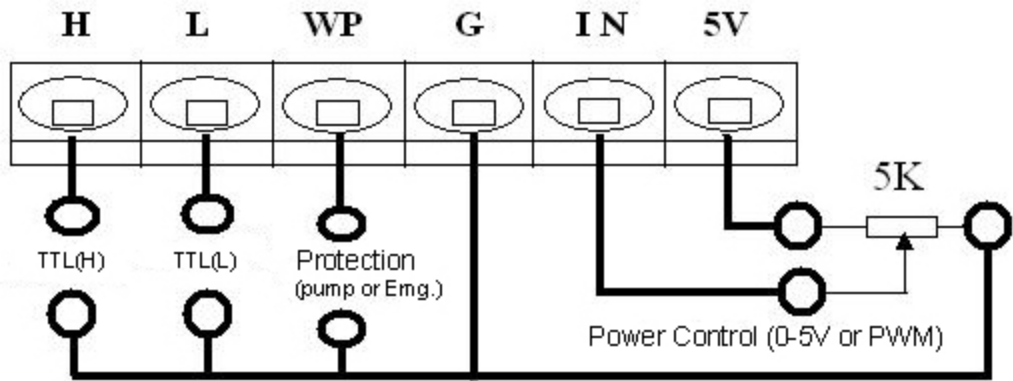

General diagram

Example:

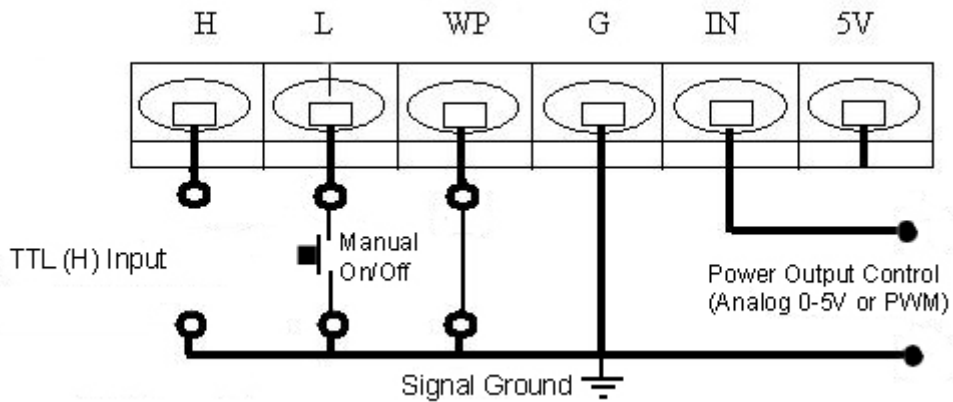

High Level Input Control diagram

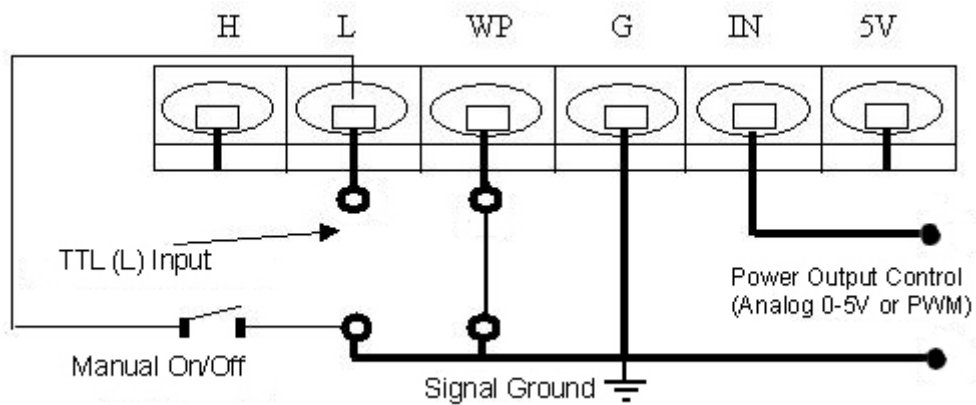

Low Level Input Control Diagram

TTL (H)	TTL(L)	WP	Control (IN)	Output
Not Connected	Low(<0.3V)	Low(<0.3V)	0-5V	Pmin - Pmax
	High(>0.3V)		0-5V	0
Low(<0.3V)	Not Connected		0-5V	0
High(>0.3V)			0-5V	Pmin- Pmax
Don't Care	Don't care	Open	Don't care	0

Regardless of which way is using, High Level or Low Level configuration, there is always two ways to control the power:

- 1) TTL: 20KHz- 50KHz, 5V PWM (by controlling the pulse width)
- 2) Analog: 0-5V DC.

Caution

- Check and clear any loose contact/screws as the unit may get damaged during transportation.
- Make sure that the case of the power supply is grounded when in operation.
- Make sure that the output terminal is connected firmly before power up, otherwise it will cause 'arc' or spark which is very dangerous. Electric shock may occur if an arc occurred.
- Do not touch the output terminals as it is carrying very high voltage as high as 30KV!
- For maintenance, make sure that the power is off and the power cord is unplugged.
- Highly recommend to install a water pump sensor to the power supply (WP) to protect a laser from over heat.