

ITEM	PART NUMBER	QTY	DESCRIPTION	LENGTH	LENGTH EXT	UNIT PRICE	PRICE EXT
1	GANTRY	1	GANTRY ASSEMBLY				
2	EXTR_GANTRY	1	MISUMI HFSF5-2040	1000.000	1000.000	9.900	9.900
3	V_RAIL_32	2	V RAIL 32LG	32.000	64.000	1.000	2.000
4	LASER_CAR	1	LASER CAR ASSEMBLY	0.000	0.000	0.000	0.000
5	LASER_CAR	1	LASER HEAD CAR PLATE	0.000	0.000	1.000	1.000
6	SPACER	3	SPACER	0.000	0.000	0.250	0.750
7	V_WHEEL	3	V WHEEL	0.000	0.000	9.950	29.850
8	LENS_MOUNT	1	LASER MIRROR/LENS MOUNT	0.000	0.000	18.000	18.000
9	GANTRY_MOTOR_MOUNT	1	GANTRY_MOTOR_MNT	0.000	0.000	1.000	1.000
10	V_WHEEL	6	V WHEEL	0.000	0.000	9.950	59.700
11	NEMA_23	1	STEPPER MOTOR NEMA 23	0.000	0.000	20.000	20.000
12	GANTRY_WHEEL_BRACKET	1	GANTRY_WHEEL_BRKT	0.000	0.000	1.000	1.000
13	IDLER_BRKT	1	IDLER PULLER BRACKET	0.000	0.000	1.000	1.000
14	A 6A 3-12DF02508	1	TIMING PULLY .2 PITCH 12 TOOTH	0.000	0.000	9.390	9.390
15	A 6R 3-315025	1	TIMING BELT 315 TOOTH	315.000	315.000	8.820	8.820
16	SPACER	3	SPACER	0.000	0.000	0.250	0.750
17	bearing_8_22_7	1	BEARING 8mm 22mm 7mm	0.000	0.000	3.000	3.000
18	WASHER_FENDER_312	1	FENDER WASHER	0.000	0.000	0.000	0.000
							166.160

REVISIONS				APPROVALS		
SYM	DESCRIPTION	BY	DATE	ENGRG	PROD	Q.A.
1	ORIGINAL	BJD	7/2/2009			
2	REVISED DRIVE DESIGN	BJD	7/6/2009			
3	Added reference dims	BJD	7/9/09			

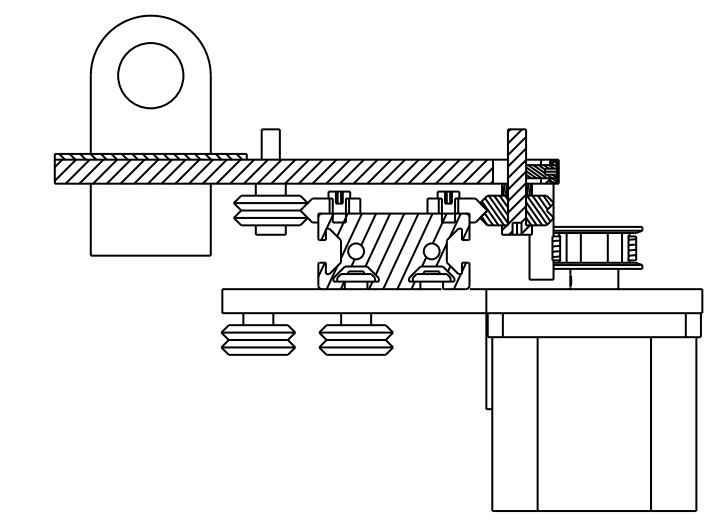

SECTION A-A

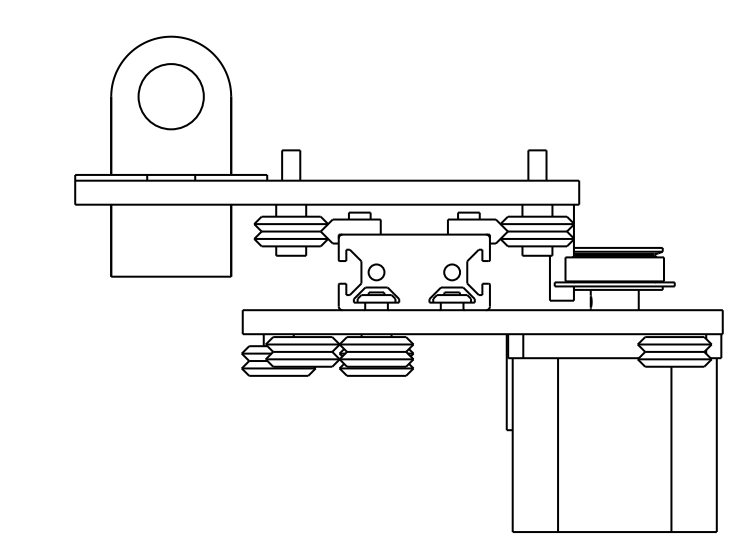
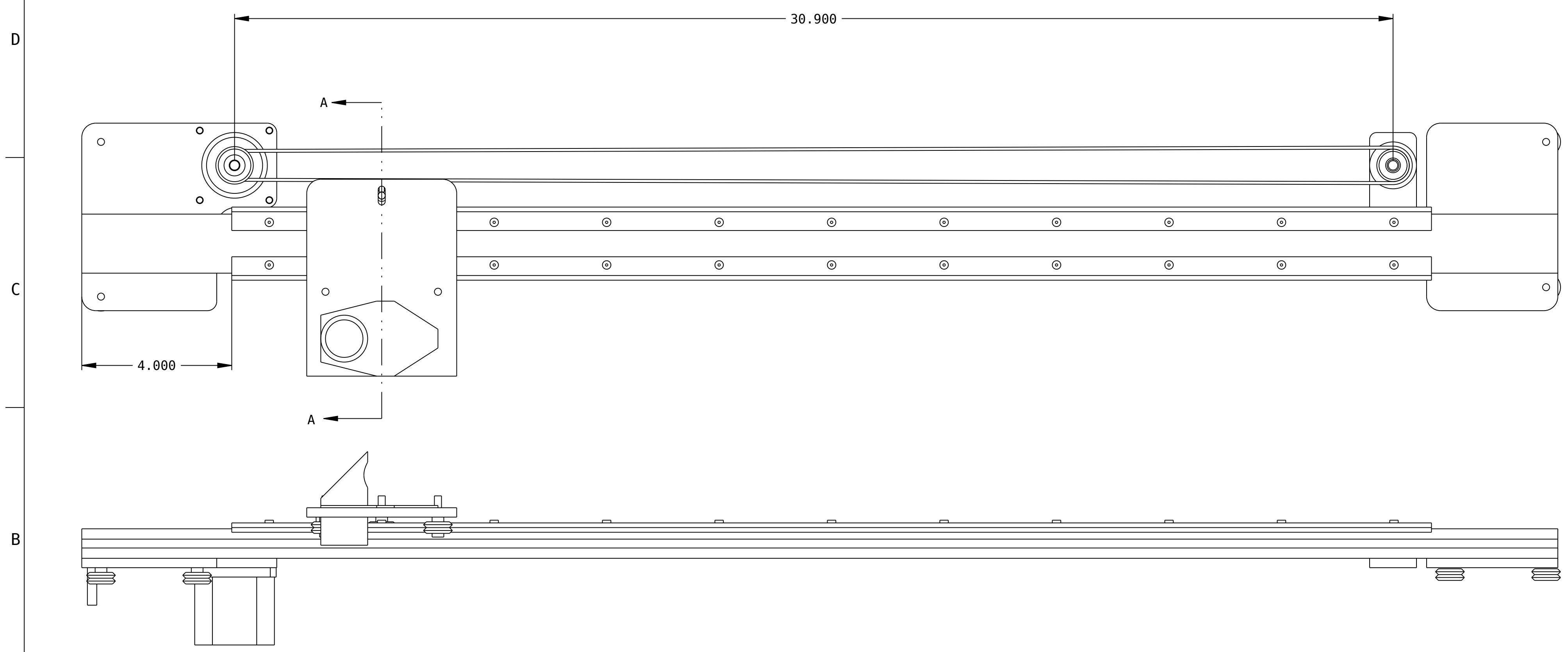
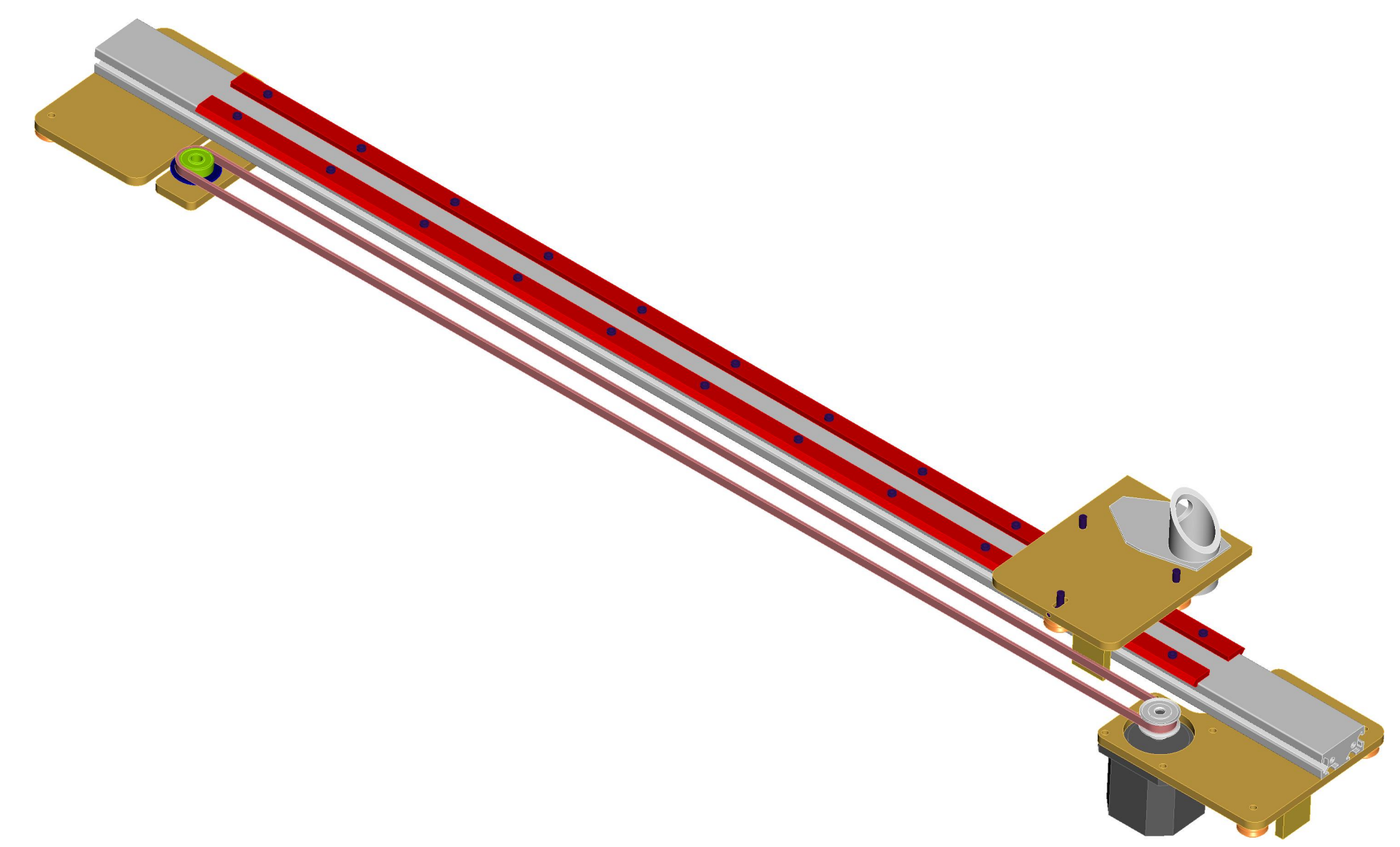

UNLESS OTHERWISE SPECIFIED:		DRAWN	BJD	7/2/2009	GANTRY ASSEMBLY		GANTRY	
FRACTIONAL	± 1/32	DO NOT SCALE	CHECKER					
DECIMAL	.xxx ± .010		MECH. ENGR.					
ANGULAR	.xx ± .020 ± 1/2°		ELEC. ENGR.					
MATERIAL:		PROJ. ENGR.						
FINISH:		CHIEF ENGR.						
SPEC:					SCALE	FSCM NO. 16469	SHEET 1 OF 1	